

OWNER'S GUIDE &

INSTALLATION INSTRUCTIONS

Transom-mount Depth Transducer or TRIDUCER® Multisensor with Integral Release Bracket

Model P66

U. S. Patents: 5,606,253; 5,719,824

04/10

17-247-03 rev. 03

WARNING: Always wear safety goggles and a dust mask when installing to avoid personal injury.

CAUTION: Never use solvents. Cleaners, fuel, sealants, paint, and other products may contain strong solvents, such as acetone, which attack many plastics, greatly reducing their strength.

IMPORTANT: Read the instructions completely before proceeding with the installation. These instructions supersede any other instructions in your instrument manual if they differ.

Applications

- Not recommended for boats with large or twin-screw inboard engine(s)
- Not recommended for stepped hulls
- Good operation up to 44 kn (50MPH)
- Vertically orients sound beam on hull with deadrise angle up to 30°
- Adjusts to transom angles from 2°–22°
- Bracket protects sensor from frontal impact only

Tools & Materials

- Safety goggles
- Dust mask
- Scissors
- Masking tape
- Electric drill
- Drill bits:
 - Bracket holes 4mm, #23, or 9/64"
 - Transom hole (optional) 21mm or 13/16"
 - Cable clamp holes 3mm or 1/8"
- Angle finder
- Marine sealant
- Screwdrivers
- Straight edge
- Pencil
- Grommet(s) (some installations)
- Cable ties
- Water-based anti-fouling paint (**mandatory in salt water**)

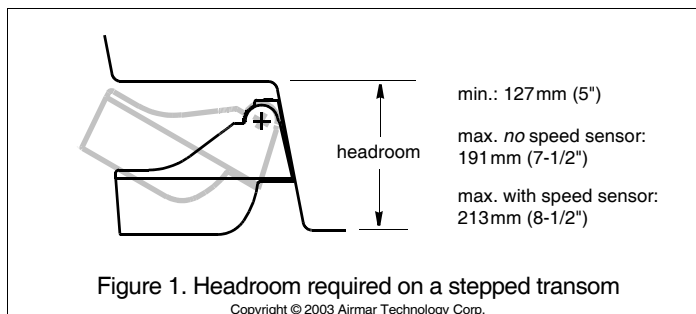

Record the information found on the cable tag for future reference.

Part No. _____ Date _____ Frequency _____ kHz

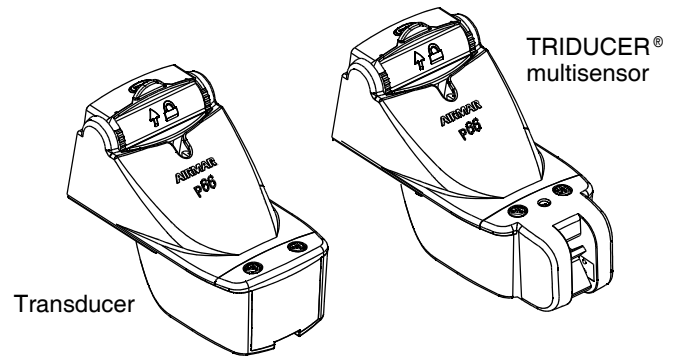

Pretest Speed & Temperature Functions

Connect the multisensor to the instrument and spin the paddlewheel. Check for a speed reading and the approximate air temperature. If there is no reading(s) or it is inaccurate, return the product to your place of purchase.

Mounting Location

CAUTION: Do not mount in an area of turbulence or bubbles. Near water intake or discharge openings. Behind strakes, struts, fittings, or hull irregularities.

CAUTION: Avoid mounting the sensor where the boat may be supported during trailering, launching, hauling, or storage.

- For the best performance, the sensor must be in contact with smooth water. To identify an area of clean water, observe the water flow off the transom while the boat is underway.
- Allow headroom space above the bracket for it to release and rotate the sensor upward (see Figure 1).
- Mount the sensor as close to the centerline (keel) of the boat as possible to ensure the transducer's face remains in the water when the boat is turning.
 - **Single drive boat**—Mount at least 75 mm (3") beyond the swing radius of the propeller (see Figure 2). The starboard side where the propeller blades are moving downward is preferred.
 - **Twin drive boat**—Mount the sensor between the drives.

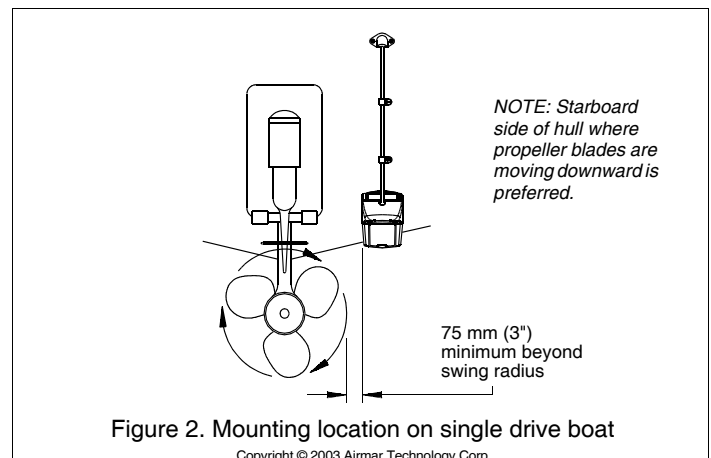

Figure 3. Template

for starboard side of boat

Drill at locations labeled "B"
for transom angles 16° through 22°
(most small aluminum boats)



Drill at locations labeled "A"
for transom angles 2° through 15°
(most boats)

Align arrow with bottom of transom



parallel to waterline

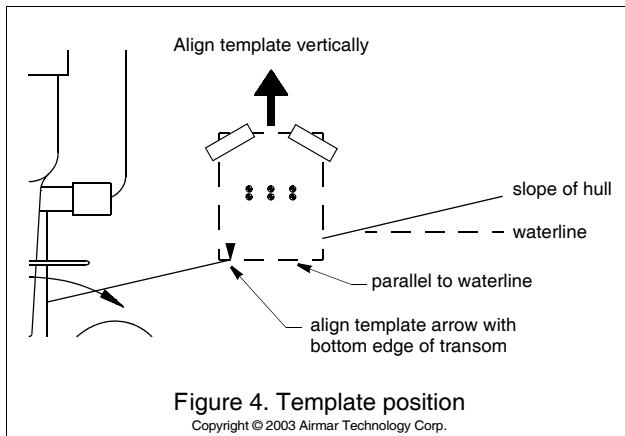

Figure 4. Template position
Copyright © 2003 Airmar Technology Corp.

Installation

WARNING: Always wear safety goggles and a dust mask.

CAUTION: Install the bracket before attaching the sensor.

Hole Drilling

1. Cut out the template (see Figure 3).
2. At the selected location on the starboard side of the hull, position the template, so the arrow at the bottom is aligned with the bottom edge of the transom (see Figure 4). *Being sure the template is parallel to the waterline, tape it in place.*
3. Using a 4 mm, #23, or 9/64" bit, drill three holes 22mm (7/8") deep at the locations indicated. To prevent drilling too deeply, wrap masking tape around the bit 22mm (7/8") from the point.
Fiberglass hull—Minimize surface cracking by running the drill in reverse until the gelcoat is penetrated.

Plastic Shim

- **Standard transom** (13° transom angle)—The bracket is designed for a standard 13° transom angle. The shim is NOT needed for this installation. Go to "Mounting the Bracket."
- **Stepped transom and jet boats** (3° transom angle) —Use the shim with the taper *down*.
- **Small aluminum and fiberglass boats** (20° transom angle)—Use the shim with the taper *up*.
- **If you are unsure about using the shim**, do one of the following:
 - Measure the transom angle of your boat using an angle finder. Then follow the instructions above for your transom angle.
 - Experiment with the shim. Follow the instructions: "Mounting the Bracket", "Attaching the Sensor to the Bracket", and "Checking the Angle and Projection."

Mounting the Bracket

1. Apply marine sealant to the threads of the three, #10 x 1-3/4", self-tapping screws to prevent water seepage into the transom (see Figure 5). Screw the bracket (and shim if needed) to the hull. *Do not tighten the screws.*
2. Using the vertical adjustment space on the bracket slots, slide the bracket up or down until the distance between the bottom left corner and the bottom of the transom equals 38mm (1-1/2"). Tighten the screws.

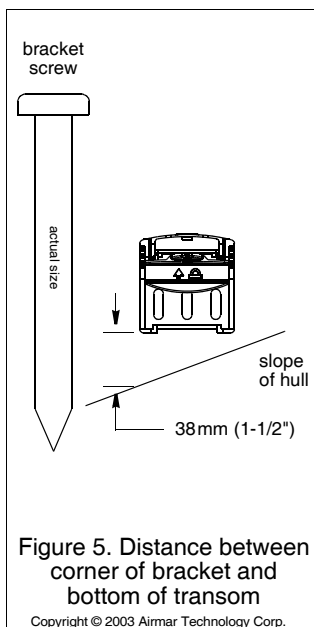

Figure 5. Distance between corner of bracket and bottom of transom
Copyright © 2003 Airmar Technology Corp.

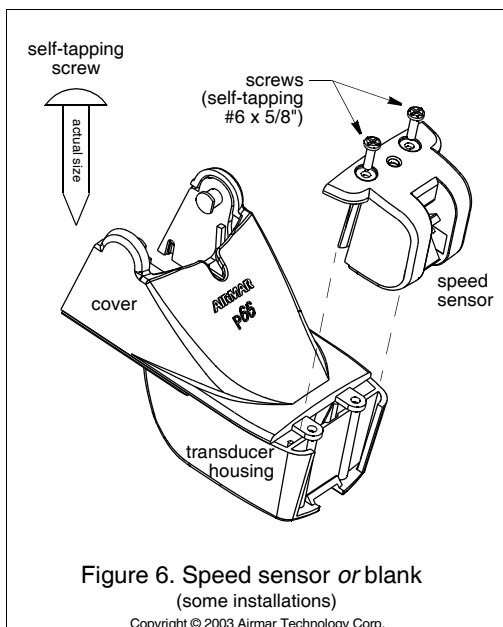

Figure 6. Speed sensor or blank (some installations)
Copyright © 2003 Airmar Technology Corp.

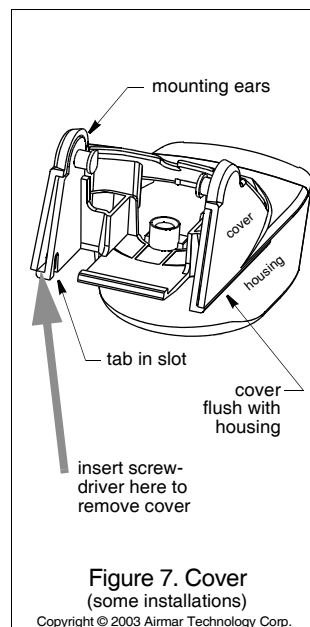

Figure 7. Cover (some installations)
Copyright © 2003 Airmar Technology Corp.

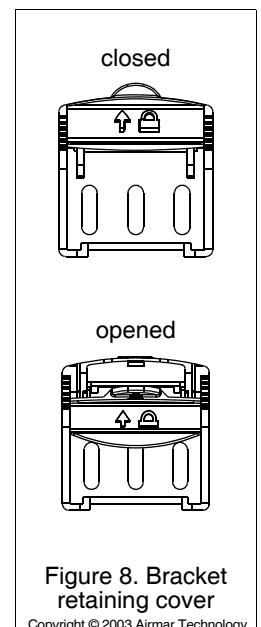

Figure 8. Bracket retaining cover
Copyright © 2003 Airmar Technology

Stepped Transom Only

If there is insufficient headroom under the step for the sensor to fully release, remove the cover before proceeding (see Figure 1, maximum headroom). This is necessary to access the bracket screws at a later time.

1. Remove the two screws that hold the speed sensor onto the transducer housing (see Figure 6).
2. The paddlewheel assembly is a loose slip fit. Carefully, slide the speed sensor upward while keeping the paddlewheel assembly inside (see Figure 13).
3. Insert a blade screwdriver between the cover and the transducer housing (see Figure 7). Pry each side apart, in turn.
4. Lift the cover up and off.

Attaching the Sensor to the Bracket

CAUTION: The retaining cover must be closed and latched to prevent the sensor from coming off the bracket when the boat is underway.

1. If the retaining cover is closed, open it by depressing the latch and rotating the cover downward (see Figure 8).
2. Insert the sensor's pivot posts into the slots in the top of the bracket (see Figure 9). Push down until the posts click into place.
3. Rotate the sensor downward until it snaps onto the bracket.
4. Close the retaining cover by rotating it upward until it latches.

Checking the Sensor Angle & Projection

CAUTION: Do not position the leading edge of the sensor lower than the trailing edge because aeration will occur.

CAUTION: Do not position the sensor deeper into the water than necessary to avoid increasing drag, spray, and water noise and reducing boat speed.

CAUTION: For boats capable of speeds above 20kn (28MPH)—The trailing edge of the sensor must be deeper in the water than the leading edge. This will ensure that the paddlewheel is in contact with the water at high speeds.

1. Using a straight edge, sight the underside of the sensor relative to the underside of the hull (see Figure 10). The stern of the sensor should be 1–3mm (1/16–1/8") below the bow of the sensor or parallel to the bottom of the hull.
2. Check that the bottom left corner of the sensor projections 3mm (1/8") below the bottom of the hull (see Figure 11).
3. If the sensor needs adjustment, release it upward (see "Releasing the Sensor" below). Adjust the bracket. Tighten the screws.

Releasing the Sensor

Do one of the following (see Figure 12):

- Using the palm of your hand, give a sharp upward blow to the underside of the transducer housing. Do not hit the speed sensor.
- Insert a blade screwdriver between the transducer housing and the bottom of the bracket (either side). Push up on the screwdriver while lifting up on the sensor.

Attaching the Cover & Blank or Speed Sensor (some installations)

1. Spread the sides of the cover horizontally (see Figure 7).
2. Slide the cover up and over the mounting ears.
3. Push the cover down until it sits flush on the transducer.
4. Squeeze the sides of the cover until the tabs snap into the slots.
5. Insert the side rails of the speed sensor or blank into the channels on the back of the transducer housing (see Figure 6). Slide it downward. Fasten the speed sensor or blank in place with the two, #6 x 5/8", self-tapping screws.

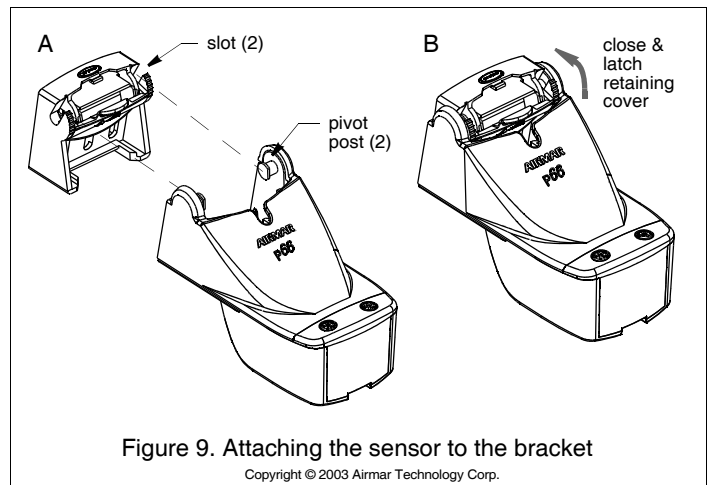

Figure 9. Attaching the sensor to the bracket

Copyright © 2003 Airmar Technology Corp.

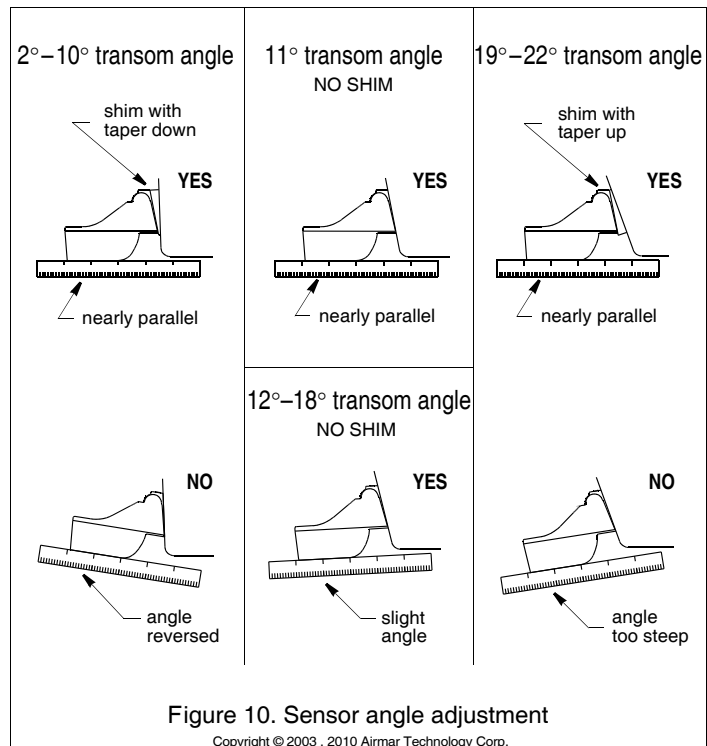

Figure 10. Sensor angle adjustment

Copyright © 2003, 2010 Airmar Technology Corp.

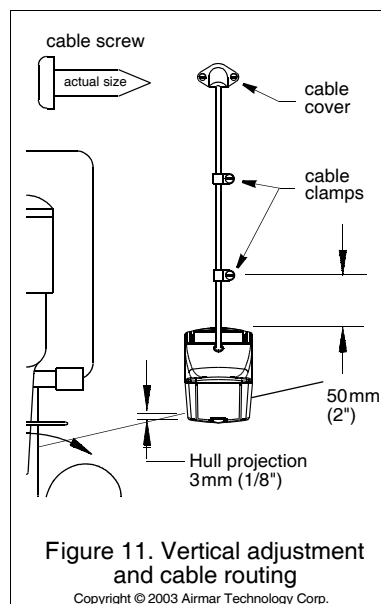

Figure 11. Vertical adjustment and cable routing

Copyright © 2003 Airmar Technology Corp.

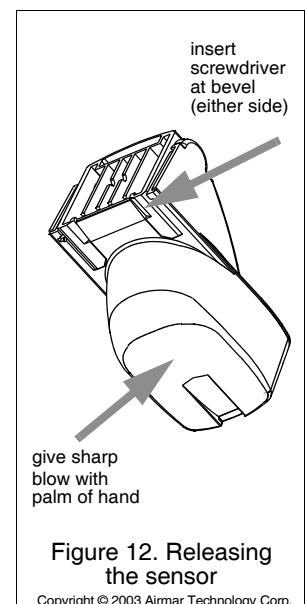

Figure 12. Releasing the sensor

Copyright © 2003 Airmar Technology Corp.

Testing on the Water

1. Become familiar with your echosounder's performance at a speed of 4kn (5MPH).
2. Gradually increase the boat speed and observe the gradual decline in performance due to turbulent water flowing over the transducer's active surface.
3. If the decline in performance is sudden (not gradual), identify the boat speed at which the onset occurred. Return the boat to this speed, then gradually increase speed while making moderate turns in both directions.
4. If the performance improves while turning to the side on which the sensor is installed, the transducer's position probably needs adjustment. It is probably in aerated water.

To improve performance, try the following *one at a time in the order given*.

- a. Increase the sensor's angle in the water. Review "Plastic Shims" and see Figure 10.
- b. Move the sensor deeper into the water in increments of 3mm (1/8") (see Figure 11).
- c. Move the sensor closer to the centerline of the boat.
Fill unused screw holes with marine sealant.

High-speed operation [above 35kn (40MPH)] may require less projection in the water to improve performance and reduce the chance that water pressure will cause the bracket to release.

5. **Calibration**—To match the speed shown on the display to the actual speed of the boat, you may need to calibrate the instrument. Refer to your instrument owner's manual.

Cable Routing

CAUTION: Do not remove the connector to ease cable routing. If the cable must be cut and spliced, use Airmar's splash-proof Junction Box No. 33-035 and follow the instructions provided. Removing the waterproof connector or cutting the cable, except when using a water-tight junction box, will void the sensor warranty.

Route the sensor cable over the transom, through a drain hole, or through a new hole drilled in the transom **above the waterline**.

1. If a hole must be drilled through the transom, choose a location **well above the waterline** (see Figure 11). Check for obstructions such as trim tabs, pumps, or wiring inside the hull. Mark the location with a pencil. Drill a hole using the appropriate size bit to accommodate the connector.
2. Route the cable over or through the transom.
3. On the outside of the hull, secure the cable against the transom using the cable clamps. Position one cable clamp 50mm (2") above the bracket and mark the mounting hole with a pencil.
4. Position the second cable clamp halfway between the first clamp and the cable hole. Mark this mounting hole.
5. If a hole has been drilled in the transom, open the appropriate slot in the cable cover. Position the cover over the cable where it enters the hull. Mark the two mounting holes.
6. At each of the marked locations, use a 3mm or 1/8" bit to drill a hole 10mm (3/8") deep. To prevent drilling too deeply, wrap masking tape around the bit 10mm (3/8") from the point.
7. Apply marine sealant to the threads of the #6 x 1/2" self-tapping screws to prevent water from seeping into the transom. If you have drilled a hole through the transom, apply marine sealant to the space around the cable where it passes through the transom.
8. Position the two cable clamps and fasten them in place. If used, push the cable cover over the cable and screw it in place.
9. Route the cable to the instrument being careful not to tear the cable jacket when passing it through the bulkhead(s) and other parts of the boat. Use grommets where appropriate. To reduce electrical interference, separate the sensor cable from other electrical wiring and the engine(s). Coil any excess cable and secure it in place with cable ties to prevent damage.
10. Refer to your echosounder owner's manual to connect the sensor to the instrument.

4

Copyright © 2000, 2010 Airmar Technology Corp. All rights reserved.

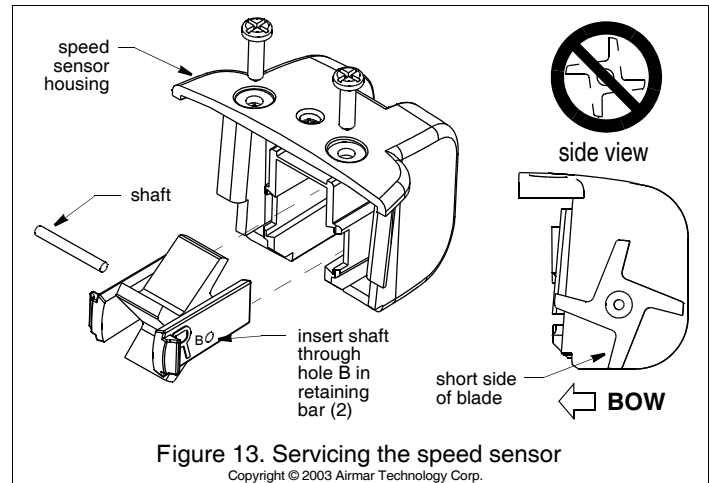

Figure 13. Servicing the speed sensor

Copyright © 2003 Airmar Technology Corp.

Checking for Leaks

WARNING: Do not leave the boat in the water unchecked for several days. When the boat is placed in the water, **immediately** check for leaks around the screws and any holes drilled in the hull. Note that very small leaks may not be readily observed.

Anti-fouling Paint

Aquatic growth can accumulate rapidly on the sensor's surface reducing performance within weeks. Surfaces exposed to salt water that do not interlock, must be coated with anti-fouling paint. Use **water-based** anti-fouling paint only. Never use ketone based paint, since ketones can attack many types of plastic possibly causing damage to the transducer. Apply paint every 6 months or at the beginning of each boating season.

Maintenance, Repair & Parts

Clean the transducer's surface with a Scotch-Brite® scour pad and mild household detergent taking care to avoid making scratches. If the fouling is severe, lightly wet sand with fine grade wet/dry paper.

Servicing the Speed Sensor

If the paddlewheel becomes fouled or inoperable, remove it for cleaning. Remove the two screws from the speed sensor (see Figure 13). Slide it upward to remove it from the transducer housing. Grasp the two retaining bars and pull to access the shaft.

After cleaning, slide the paddlewheel onto the shaft. *Orient the short side of the paddlewheel blade as shown on the side view.* It must be oriented correctly to measure the boat's speed. Fit the shaft into the holes marked "B" in the retaining bars. *Note: There is a left retaining bar marked with an L and a right retaining bar marked with an R.* Slide the assembly into the speed sensor housing. *Note: The interior of the housing is marked with a corresponding L and R.* Re-attach the speed sensor.

Sensor Replacement & Parts

The information needed to order a replacement sensor is printed on the cable tag. Do not remove this tag. When ordering, specify the part number, date, and frequency in kHz. For convenient reference, record this information on the top of page one.

Replace broken or worn parts immediately. The water-lubricated paddlewheel bearings have a life of up to 5 years on low-speed boats [less than 10kn (11MPH)] and 2 years on high-speed vessels. Some depth/temperature units can be upgraded by adding a speed sensor.

Part	Part Number
Paddlewheel Kit	33-473-01
Bracket and Wedge Kit	33-479-01
Speed Sensor Kit	33-346-03

Obtain parts from your instrument manufacturer or marine dealer.

Gemeco (USA)	Tel: 843.210.7000
	Fax: 843.210.7170
	email: sales@gemeco.com
Airmar EMEA (Europe, Middle East, Africa)	Tel: +33.(0)2.23.52.06.48
	Fax: +33.(0)2.23.52.06.49
	email: sales@airmar-emea.com