

OWNER'S GUIDE & INSTALLATION INSTRUCTIONS

In-hull, Adjustable Angle Depth Transducer

Model P79

U.S. Patent No. 6,201,767 B1; EP 1 118 074 B1

03/08
17-217-01 rev. 10

IMPORTANT: Please read the instructions completely before proceeding with the installation. These instructions supersede any other instructions in your instrument manual if they differ.

CAUTION: Never use solvents!

Cleaners, fuel, paint, sealants, and other products may contain strong solvents, such as acetone, which attack many plastics greatly reducing their strength.

Applications

- Fiberglass hulls only
- Recommended for high-speed powerboats and racing sailboats
- Accommodates a deadrise angle up to 22°

Tools & Materials

- Adhesive tape
- Pole
- Detergent
- Weak solvent (such as alcohol)
- Safety goggles (some installations)
- Dust mask (some installations)
- Disk sander (some installations)
- Thin sealable plastic bag (optional)
- Twist-tie (optional)
- Water-based lubricant (such as K-Y® jelly) (optional)
- Angle finder or digital level
- Carpenter's square
- Pencil
- Silicone sealant (such as GE Silicone I or Silicone II)
- Screwdriver
- Petroleum jelly (such as Vaseline® brand)
- Propylene glycol (non-toxic antifreeze/coolant) 71 ml (2.4 fl. oz.)
- Level
- Installation in a cored fiberglass hull (see page 4):
 - Drill
 - Hole saw 100mm or 4"
 - Miniature disk sander
 - Casting epoxy (Polypoxy #7035/7040) or resin
 - Paper cup
 - Stirrer

Record the information found on the cable tag for future reference.

Part No. _____ Date _____ Frequency _____ kHz

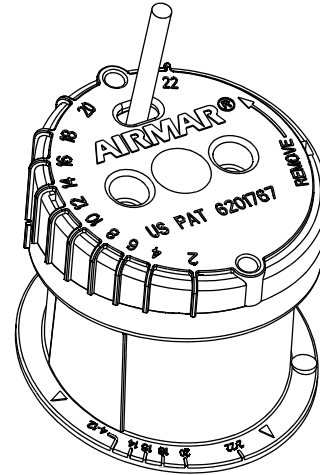

Mounting Location

About Fiberglass Hulls

CAUTION: The fiberglass hull below the transducer must be solid.

Since the hull absorbs acoustic energy, transmitting through the hull reduces the transducer's performance. Fiberglass hulls are often reinforced in places for added strength or to reduce weight. These cored areas contain balsa wood or structural foam which are poor sound conductors. *Do not locate the transducer over coring.*

Placement

CAUTION: Do not mount the transducer near water intake or discharge openings or behind strakes, fittings, or hull irregularities that will disturb the water flow.

Choose a location:

- Where the fiberglass is solid (no air bubbles are trapped in the fiberglass resin) and where no coring, flotation material, or dead air space is sandwiched between the inside skin and outer skin of the hull.
- Where the hull below the transducer will be in contact with the water at all times.
- Where the water flowing under the hull is smoothest with a minimum of bubbles and turbulence (especially at high speeds).
- Away from interference caused by power and radiation sources such as: the propeller(s) and shaft(s), other machinery, other echosounders, and other cables. The lower the noise level, the higher the echosounder gain setting that can be used.
- Where the transducer beam will *not* be blocked by the keel or propeller shaft(s).
- Where the deadrise angle does *not* exceed 22°.
- Where there is space inside the vessel for the height of the unit, tightening the locking ring, and removing the transducer.

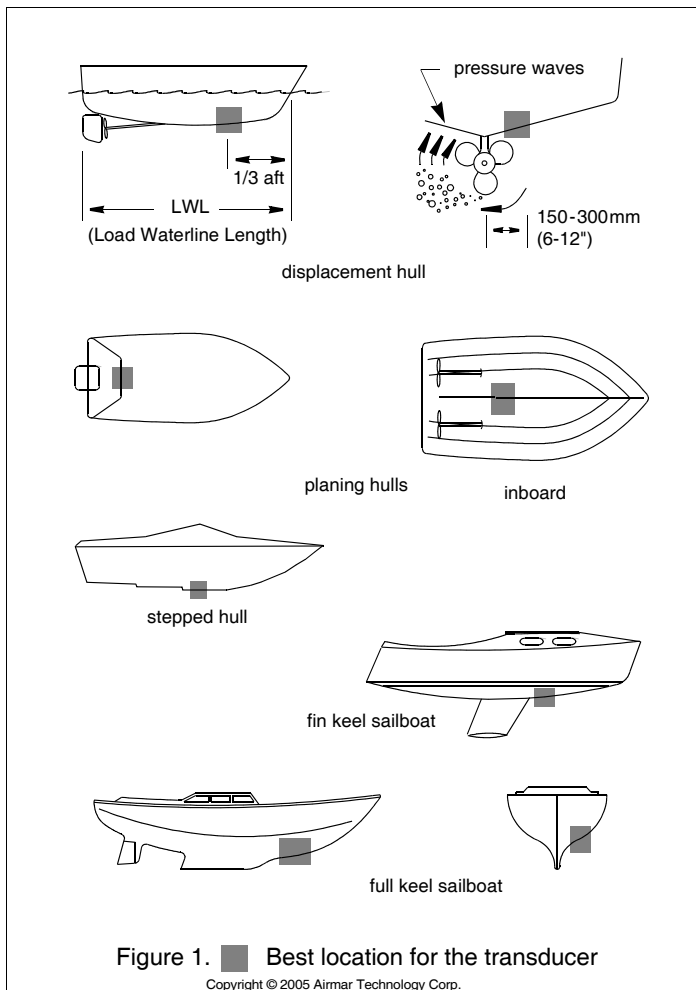

Figure 1. ■ Best location for the transducer

Copyright © 2005 Airmar Technology Corp.

Boat Types (see Figure 1)

- **Displacement hull powerboat**—Locate 1/3 aft LWL and 150–300mm (6–12") off the centerline on the side of the hull where the propeller blades are moving downward.
- **Planing hull powerboat**—Mount well aft, on or near the centerline, and *well inboard of the first set of lifting strakes* to insure that the transducer is in contact with the water at high speeds. Mount on the side of the hull where the propeller blades are moving downward.
Outboard and I/O—Mount just forward of the engine(s).
Inboard—Mount well ahead of the propeller(s) and shaft(s).
Stepped hull—Mount just ahead of the first step.

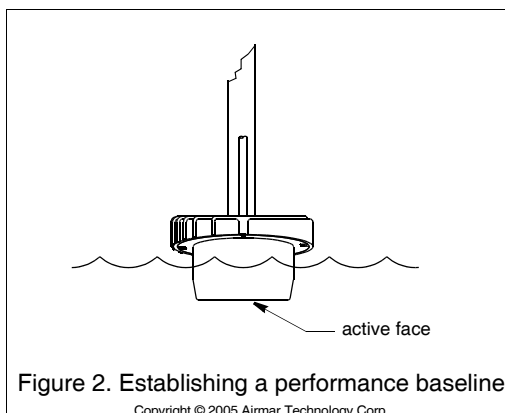

Figure 2. Establishing a performance baseline

Copyright © 2005 Airmar Technology Corp.

- **Fin keel sailboat**—Mount to the side of the centerline and forward of the fin keel 300–600mm (1–2').
- **Full keel sailboat**—Locate amidships and away from the keel at the point of minimum deadrise angle.

Test the Selected Mounting Location

Establishing a Performance Baseline

The results of this test are used as a basis of comparison to determine the best in-hull location for the transducer.

CAUTION: Never pull, carry, or hold the transducer by the cable as this may sever internal connections.

1. Take the boat to the maximum depth in which you will be operating the echosounder. If deep water is not available, find a location with at least 30m (100').
2. Connect the transducer to the echosounder.
3. Tape the transducer to a pole with the cable side up. Hold it over the side of the boat with the active face submerged in the water (see Figure 2). *Be sure to keep the active face of the transducer parallel to the surface of the water and fully submerged.*
4. Observe the echosounder's performance and the depth reading.

Testing the Mounting Location

While the boat is at the same site (depth of water), test the transducer inside the hull at the mounting location. Use one of the methods below:

A. If the transducer will be located near the stern and the boat has a minimum deadrise angle—Clean away any large build-up of dirt and/or grease using detergent or a weak solvent such as alcohol. Place the transducer against the hull and allow bilge water to cover the surface where they touch (see Figure 3-A).

B. WARNING: Always wear safety goggles and a dust mask.

For a moderate deadrise angle—If the hull surface is not smooth, grind it with a disc sander. Place the transducer inside a thin plastic bag. Partially fill the bag with water and close it tightly with a twist-tie. Wet the surface of the hull and press the active face of the transducer against it through the bag (see Figure 3-B).

C. Warning: Always wear safety goggles and a dust mask.

For any location—If the hull surface is not smooth, grind it with a disc sander. Coat the active face of the transducer with a water-based lubricant (such as K-Y® jelly). With a twisting motion, press the face firmly against the hull (see Figure 3-C). After testing, wipe all traces of the lubricant from the transducer's face.

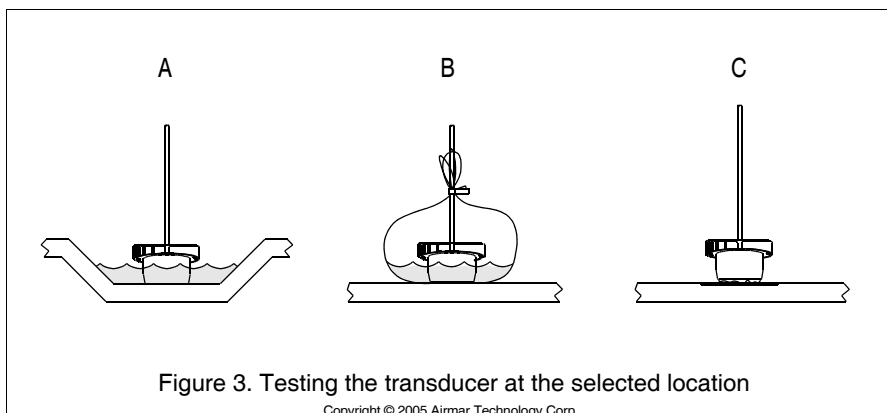
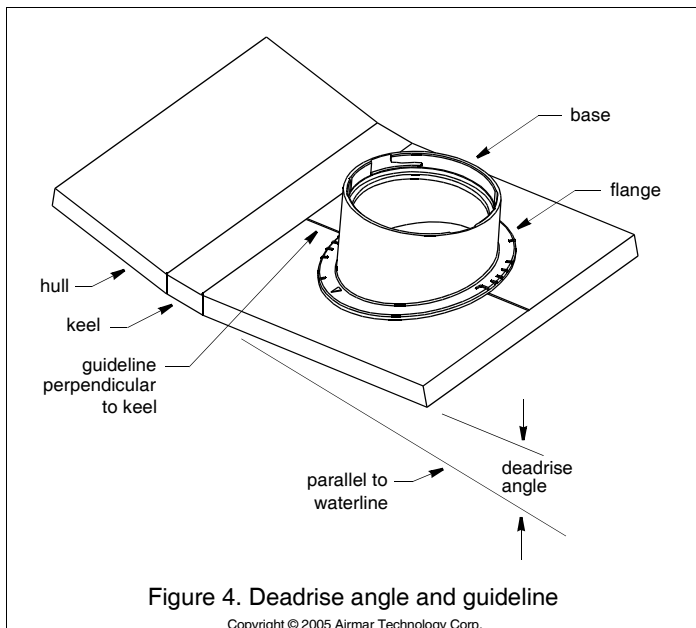

Figure 3. Testing the transducer at the selected location

Copyright © 2005 Airmar Technology Corp.



Observe the echosounder's performance, and compare it to the baseline. Look for a stable depth reading that is similar to the baseline. Compare the thickness and intensity of the bottom trace.

If the performance is close to the baseline, this is a good mounting location. Remember, some energy is lost transmitting through the hull. If the test reading differs markedly from the baseline, you will need to find another location to install the transducer.

Note: If there is no reading or it is erratic, the transducer may be positioned over coring that is absorbing the acoustic energy. Choose another location. If no other location is available, check with the boat manufacturer to be certain coring is present before proceeding with the instructions for "Installation in a Cored Fiberglass Hull" on page 4.

Installation

1. Measure the deadrise angle of the hull at the selected location using an angle finder or digital level (see Figure 4). Measure carefully, since the installed transducer must be within 5° of vertical.

WARNING: Always wear safety goggles and a dust mask.

2. The hull surface to be bonded must be smooth and free of paint or any other finish. If the surface is rough, use a disk sander to smooth an area 100mm (4") in diameter.
3. To ensure a tight bond, clean and dry both the selected area and the underside of the base. Remove any dust, grease, or oil with a weak solvent, such as alcohol.
4. Using a carpenter's square, draw a line on the hull perpendicular to the keel through the center of the mounting location. This will be used as a guideline to orient the base.
5. The numbers on the flange of the base represent deadrise angles. Identify the number that most closely corresponds to the deadrise angle of your hull. Find its match on the opposite side of the flange. Keeping the keel direction arrows on the side of the base nearest the keel, align the two raised marks indicating your deadrise angle with the guideline drawn on the hull (see Figure 5).

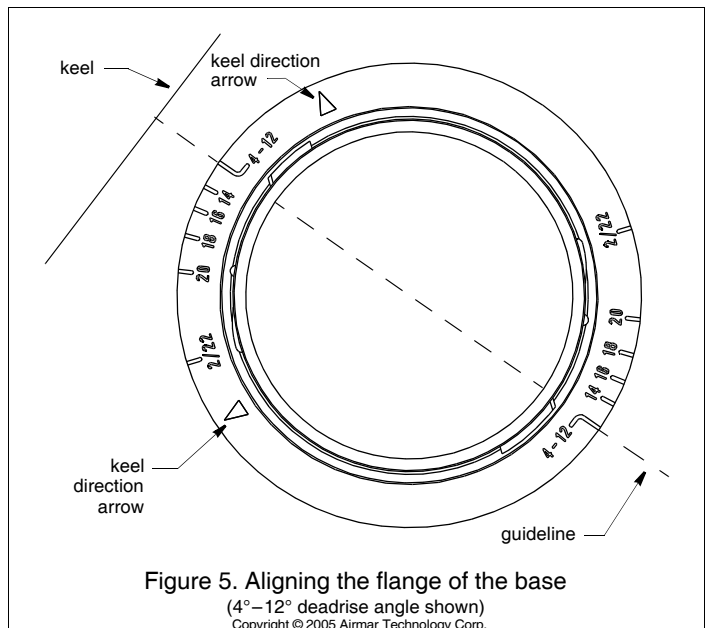

CAUTION: The base must be liquid-tight. Do Not use an epoxy adhesive because it is too brittle.

6. When you are satisfied that the location of the transducer is optimal and the orientation of the base corresponds to the deadrise angle of your boat, apply a generous bead of silicone sealant to the underside of the flange of the base. (Follow the sealant manufacturer's instructions for its use.) Press the flange firmly in place to form a liquid-tight seal. Allow the sealant to cure.
7. Slide the transducer into the locking ring (see Figure 6). Turn the transducer until the rib that most closely corresponds to the deadrise angle of your hull is aligned with the angle indicator on the locking ring. To secure the transducer to the locking ring, insert the two screws. **Do not over-tighten the screws.**

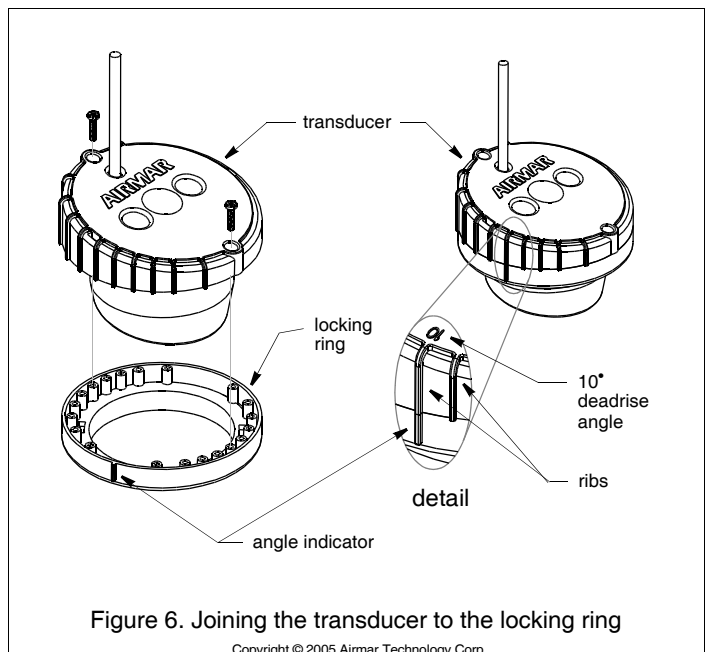

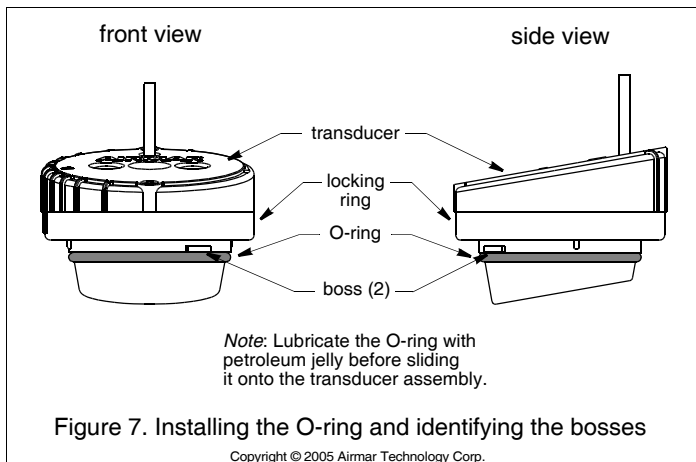

8. Lubricate the O-ring with petroleum jelly (Vaseline®). This will help to seal the assembly and prevent the fill-liquid from leaking. Slide the O-ring onto the transducer assembly (see Figure 7).
9. After the sealant on the base has cured, pour 71 ml (2.4 fl. oz.) of propylene glycol into the base. *Be sure* to follow the manufacturer's directions for use.

CAUTION: The top of the transducer must be level when the installation is complete.

10. With the angle indicator on the keel side, lock the transducer assembly into the base (see Figure 8). (The bosses on the locking ring fit into the notches in the base.) Press down and rotate clockwise until it is seated. When the transducer is installed correctly, the top will be level. If the deadrise angle is shallow, the transducer may appear to be level even if it is not. Use a level to check the installation.

11. Route the cable to the echosounder *being careful* not to tear the cable jacket when passing it through the bulkhead and other parts of the boat. To reduce electrical interference, separate the transducer cable from other electrical wiring and sources of electrical noise.

Note: Some transducers are equipped with a short cable, about 1 m (3'), and an extension cable. *Be sure to locate the mated 3 pin connectors well above the bilge waterline.* To facilitate this, use one of the two cable clamps supplied on either side of the connection.

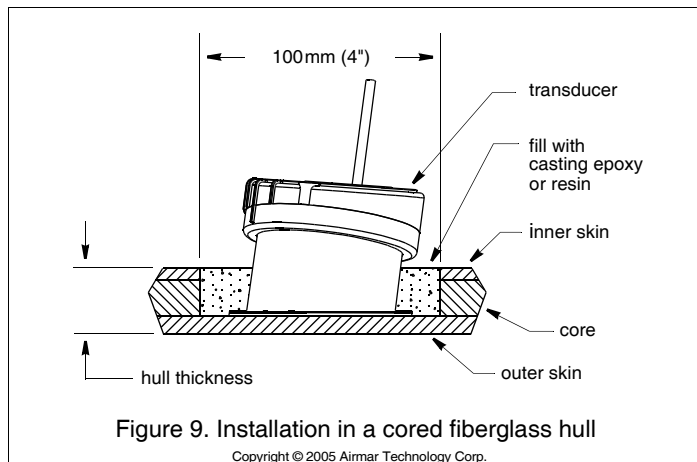
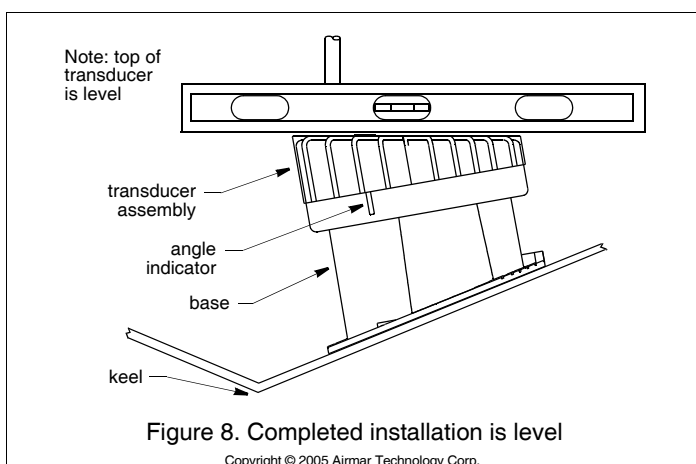

Installation in a Cored Fiberglass Hull

Installation in a cored hull is difficult. The objective is to bond the base to the **inside surface of the hull's outer skin** while preventing any moisture from penetrating the core.

CAUTION: There is no way to determine if the outer skin is solid (no trapped air bubbles in the fiberglass) at the selected location before cutting the inner skin.

WARNING: Always wear safety goggles and a dust mask.

1. Using a 100mm *or* 4" hole saw, cut through the **inner skin** and the core at the selected location (see Figure 9). The core material can be very soft. Apply only light pressure to the hole saw after cutting through the inner skin to avoid accidentally cutting the outer hull.
2. Remove the plug of core material, so the inner core of the hull is fully exposed. Sand the **inside surface of the outer skin** using a miniature disk sander. Slightly undercut the surrounding coring if possible.
3. Clean and dry both the **inside surface of the outer skin** and the transducer with a weak solvent, such as alcohol, to remove any dust, grease, or oil.
4. Place the base in the cavity. Fill the gap between the base and the hull with casting epoxy or resin following the manufacturer's directions for its use.
5. After the casting epoxy or resin has cured, proceed with "Installation", on page 3.

Replacement Transducer & Parts

The information needed to order a replacement transducer is printed on the cable tag. *Do not* remove this tag. When ordering, specify the part number, date, and frequency in kHz. For convenient reference, record this information on the top of page one.

Lost, broken, or worn parts should be replaced immediately.

Base & O-ring Kit 33-268-01

Obtain parts from your instrument manufacturer or marine dealer.

Gemeco Tel: 843.394.3565
(USA) Fax: 843.394.3736
email: sales@gemeco.com

Airmar EMEA Tel: +33.(0)2.23.52.06.48

(Europe, Middle East, Africa) Fax: +33.(0)2.23.52.06.49

email: sales@airmar-emea.com

AIRMAR® 35 Meadowbrook Drive, Milford, New Hampshire 03055-4613, USA
TECHNOLOGY CORPORATION www.airmar.com