

CAUTION: Disconnect the battery during installation. Tighten nuts on the back clamp only slightly more than you can tighten with your fingers. Six inch-pounds of torque are sufficient. Over tightening may result in damage to the instrument and may void your warranty.

1. A voltmeter will read most accurately if connected to or near the switched "+" positive terminal of the ignition switch thus providing a better indication of the true battery voltage (engine off) and alternator/regulator output voltage (engine running).
2. Be certain to use stranded, insulated wire not lighter than 18AWG that is approved for marine use.
3. Cut a 2-1/16" diameter hole in the dash and mount the gauge with the back clamp supplied. For connectorized cases be sure to cut a .175" wide by .115" deep notch to accept the key on the case. See detail on next page.

(See diagram on the back of this sheet for connections)

Standard Case

4. Connect a wire to the gauge stud marked "+" (positive) and secure with a nut and lock washer. Connect the opposite end to a circuit that is activated by the ignition switch. It is recommended that insulated wire terminals, preferably ring type, be used on all connections to the gauge, except light, which requires a 1/4" female blade terminal.
5. Connect a wire to the gauge stud marked "GND" (ground) and secure with a nut and lock washer. Connect the opposite end to the boat's electrical ground, generally available in several locations at or near the instrument panel.
6. Connect the blade terminal adjacent to the twist-out light assembly to the positive "+" side of the instrument lighting circuit. No separate ground is required for lighting.

NOTE: To change light bulb, twist black socket assembly one-eighth turn counterclockwise until it pops out. Bulb pulls straight out of socket assembly. A 12V voltmeter requires a GE No. 161 instrument lamp. A 24V voltmeter requires a GE No. 657 instrument lamp.

Connectorized Case

4. Insert a wire with appropriate contact to the '+' (positive) function of the connector. Connect the opposite end to a 12Vdc circuit that is activated by the ignition switch.
5. Insert a wire with appropriate contact to the ground function of the connector. Connect the opposite end to the boat's electrical ground, generally available in several locations at or near the instrument panel.
6. Insert a wire with appropriate contact to the light function of the connector. Connect the opposite end to the positive portion of the lighting circuit. Insert the connector into the back of the case. Reconnect the battery.

NOTE: To change the light bulb, twist the socket assembly counterclockwise until it pops out. A 12V voltmeter requires an Oshino OL-4186NW-001972 or equivalent lamp.

Deutsch Connector

Hookup	Function
P1.1	'+' Positive
P1.2	Lights
P1.3	N/C
P1.4	Ground
Connector	DT06-4S
Contact	1062-16-0122
Wedge Lock	W4S
Plug	114017

Packard Connector

Hookup	Function
P1.A	'+' Positive
P1.B	Lights
P1.C	Ground
P1.D	Ground (Magna-core only)
Connector	12162189
Contact	12124075
Plug	12034413

7. Reconnect the battery.

For technical assistance, contact Faria® Marine Instruments Customer Service between 8:30 AM and 5:30 PM Eastern time weekdays at (860) 848-9271 or (800) 473-2742.

Standard Case Wire connections

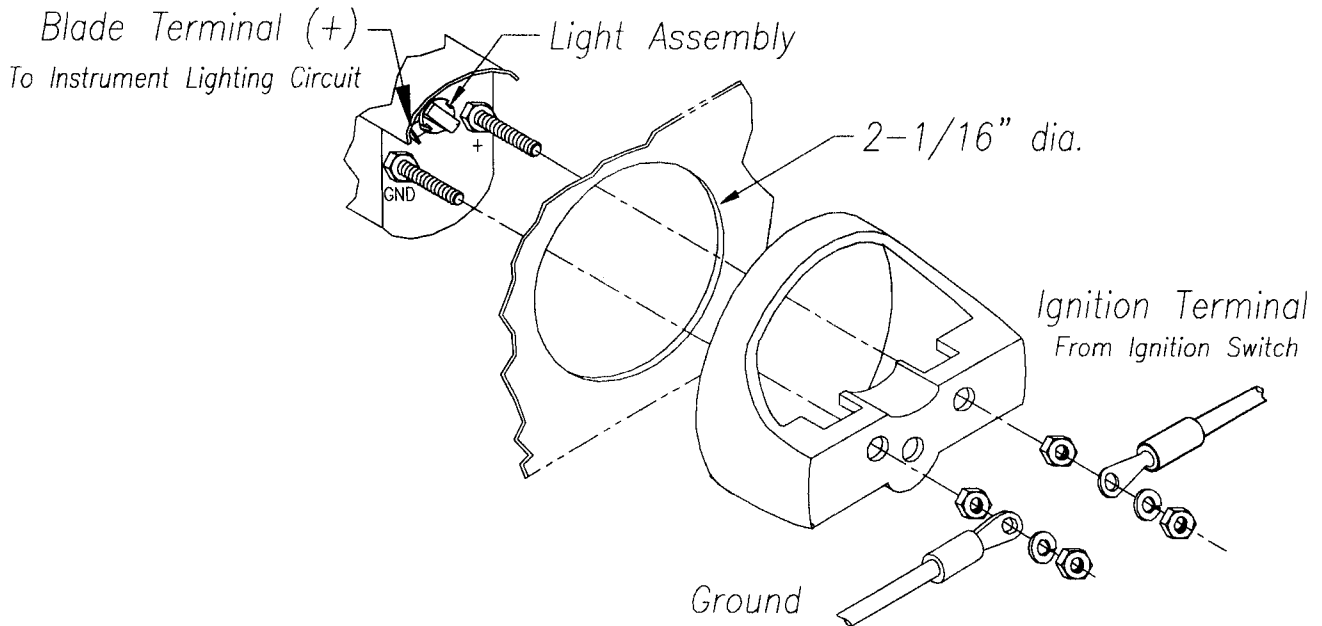

Connectorized Case Wire connections

Deutsch connector case

