

MK600 IN DASH FITTING INSTRUCTIONS

REAR VIEW

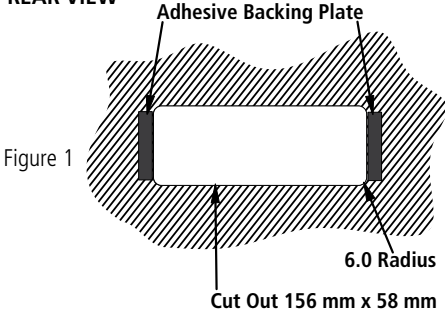

D.N. 42261-3 P.N. 310226

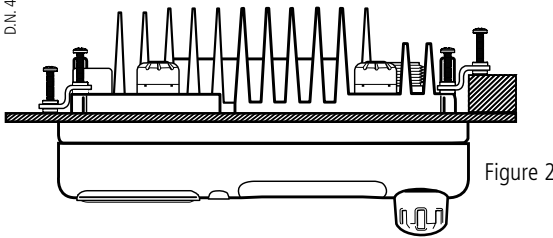

Ensure that the location selected for in dash mounting is convenient for the operator and that there is sufficient space behind the panel to accommodate the body of the radio and allow a free flow of air. Refer to page 13 of the Instruction Manual for more hints.

Once the most suitable location has been selected, mark and centre punch the cross hair in each corner and drill a 12 mm diameter hole. Mark a straight line from the outer edge of each hole to form a rectangle. Cut to the inside edge of these lines.

Remove the backing paper from the metallic backing strips exposing the self adhesive surface and fix them in position vertically at either end of the hole on the rear side of the dashboard flush with the edge. See figure 1

Place the GX600 through the hole. If the dashboard is subject to water spray it may be beneficial to apply a thin bead of sealant to prevent any water ingress between the body of the radio and the dashboard.

The S/S brackets can now be fastened to the rear panel of the GX600 with the 4 S/S self tappers supplied. Note that the brackets can be reverse mounted to allow for varying thicknesses of dashboards. See figure 2

Insert the remaining metal-thread screws so that they bear down on the two metallic backing strips and tighten until the GX600 is held firmly in place.

Connect the power lead and antenna lead as illustrated in the Instruction Manual.

Contents:

- 2 S/S brackets
- 2 adhesive backing strips
- 4 S/S self tapping screws
- 4 S/S metal-thread screws

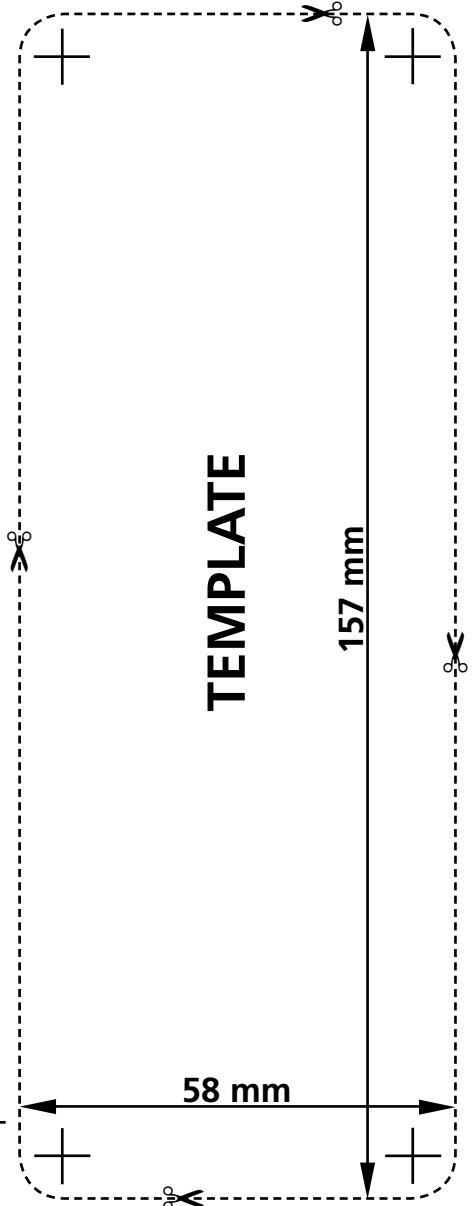

Head Office: PO Box 96, Winston Hills, NSW 2153, Australia
A division of Standard Communications Pty Ltd.

1300 463 463 gme.net.au

MK001W INSTALLATION - CUTTING TEMPLATE

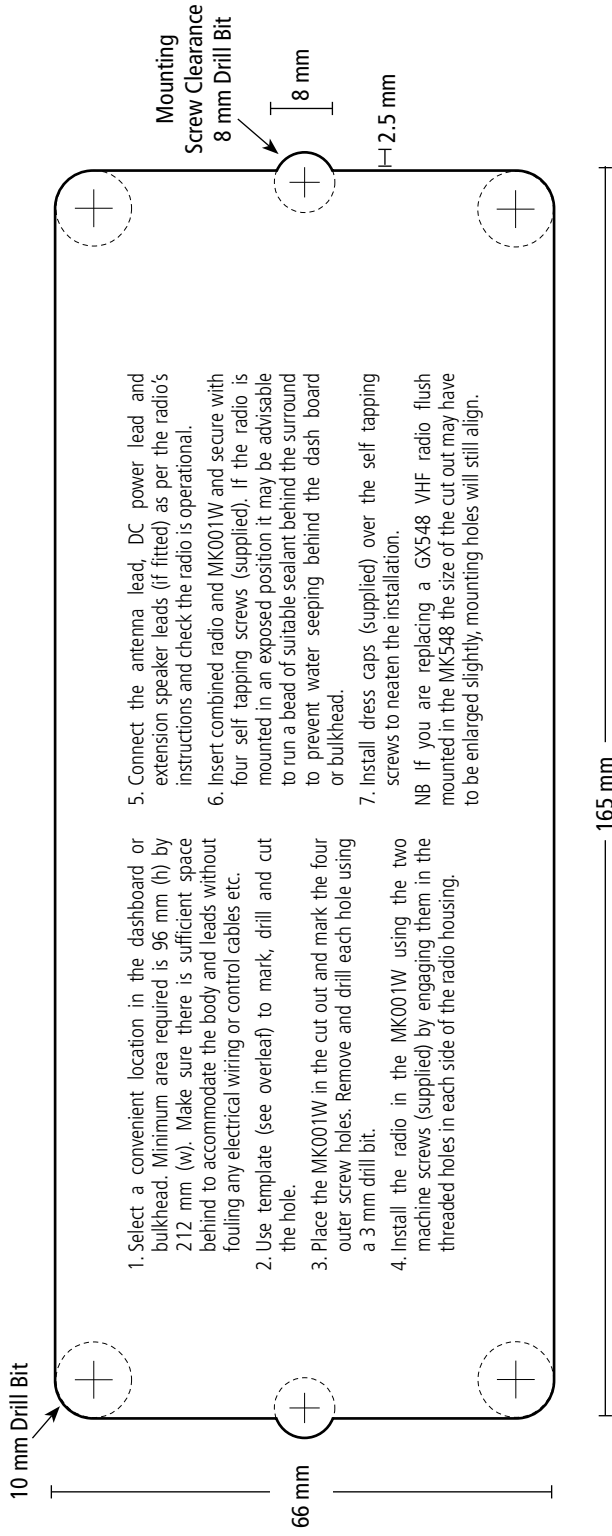

Mark and cut a hole 66 mm (h) by 165 mm (w), allowing for clearance of the two mounting screws holding the radio to the surround. Use a 10 mm drill bit to form the radius of the corners and an 8 mm drill bit for the clearance of the mounting screws.