

OWNER'S GUIDE & INSTALLATION INSTRUCTIONS

TRIDUCER® Multisensor with Valve

Models: B744V, B744VL

U.S. Patents: 4,898,029; 5,186,050, Re 33,982. Australian Patent 605,281
Canadian Patent 1,313,775. Japanese Patent 1851014.

06/07

17-438-01 rev. 02

IMPORTANT: THE MULTISENSOR MUST BE INSTALLED CAREFULLY! Please read the instructions completely before proceeding with the installation. These instructions supersede any other instructions in your instrument manual if they differ.

WARNING: The multisensor must be installed with a fairing!

A fairing that is carefully cut to fit the shape of the hull provides a sealing surface around the drilled hole. If the multisensor is not installed with a fairing, there may be insufficient surface area to seal the hull. Water may leak into the boat causing damage or possibly sinking.

WARNING: Installation with a High-Performance Fairing requires an anti-rotation bolt!

For installation using a High-Performance Fairing, follow the supplemental instructions that comes with the fairing. A High-Performance Fairing requires an anti-rotation bolt. Failure to install the anti-rotation bolt may result in the fairing rotating while the boat is underway. The effect may be violent movement and loss of steering. This could result in serious injury or death to passengers and/or damage to the boat or other property.

CAUTION: NEVER USE SOLVENTS!

Cleaners, fuel, paint, sealants, and other products may contain strong solvents, such as acetone, which attack many plastics greatly reducing their strength.

Applications

- Bronze housing recommended for fiberglass or wood hulls.
- *Never* install a bronze housing in a metal hull because electrolytic corrosion will occur.
- *Never* install a metal housing in a vessel with a positive ground system.

Record the information found on the cable tag for future reference.

Part No. _____ Date _____ Frequency _____ kHz

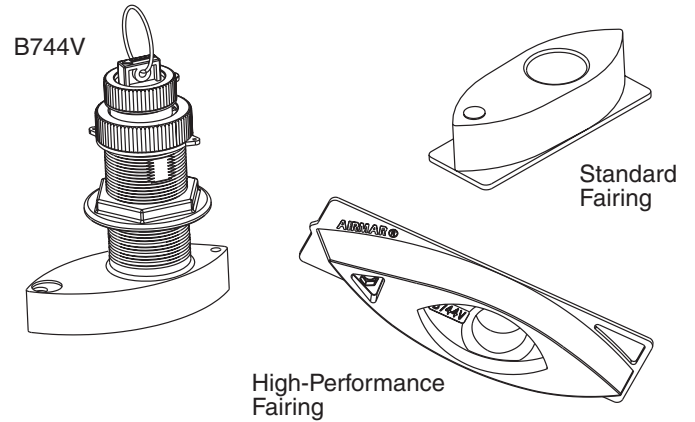

Pretest

Connect the multisensor to the instrument and spin the paddlewheel. Check for a speed reading and the approximate air temperature. If there is no reading or it is inaccurate, check the connections and repeat the test. If there is still no reading or they are inaccurate, return the product to the place of purchase.

Tools & Materials

Fairing (**MANDATORY**) (High-Performance fairing recommended)

Safety goggles

Dust mask

Electric drill

Drill bit: 3mm *or* 1/8"

Hole saw: 51mm *or* 2"

Sandpaper

Mild household detergent *or* weak solvent (such as alcohol)

Angle finder *or* digital level

Band saw *or* hand saw

Rasp *or* power tool

Marine sealant (suitable for below waterline)

Slip-joint pliers

Zip-ties

Water-based antifouling paint (**MANDATORY IN SALT WATER**)

Installation in a cored fiberglass hull (see page 4):

Hole saw for hull interior: 60mm *or* 2-3/8"

Cylinder, wax, tape, and casting epoxy

About High-Performance Fairings

Airmar recommends installing a High-Performance Fairing unless insufficient space demands a Standard Fairing. Airmar's High-Performance Fairings have a long streamlined shape that directs water around the multisensor to minimize drag. They give excellent results at all speeds and especially above 15 knots (see Replacement Multisensor & Parts on page 6).

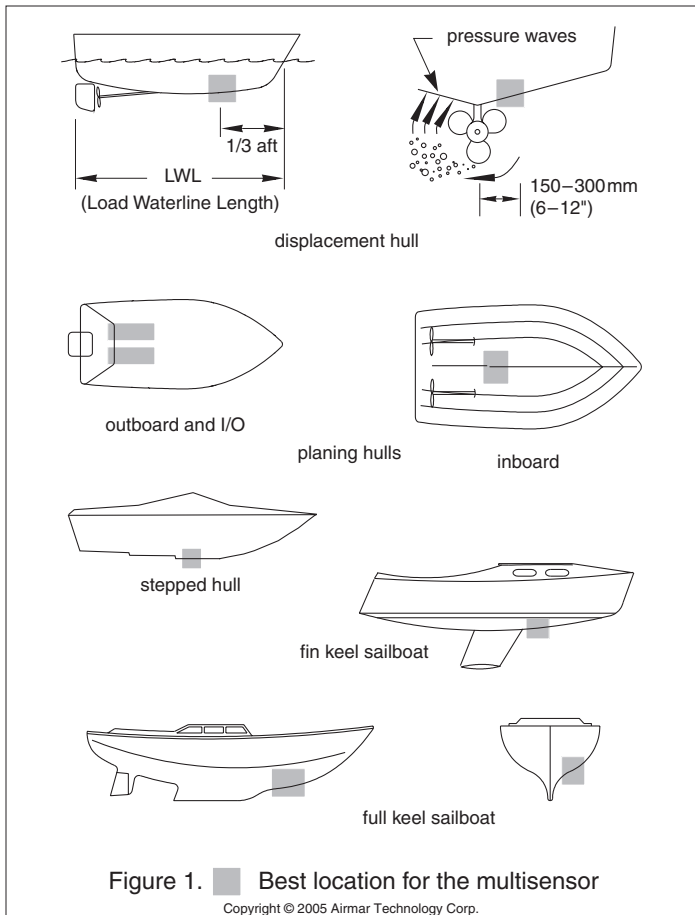

Mounting Location

- The water flowing across the hull *must* be smooth with a minimum of bubbles and turbulence (especially at high speeds).

Caution: *DO NOT MOUNT near water intake or discharge openings or behind strakes, fittings, or hull irregularities.*

- The multisensor *must* be continuously immersed in water.
- The transducer beam *must* be unobstructed by the keel or propeller shaft(s).
- Choose a location away from interference caused by power and radiation sources such as: the propeller(s) and shaft(s), other machinery, other echosounders, and other cables. The lower the noise level, the higher the echosounder gain setting that can be used.
- Choose a location with a minimum deadrise angle.
- Choose an accessible spot inside the vessel with adequate headroom for the height of the housing, tightening the nuts, and removing the insert.

Model	Min. with fairing
B744V	255mm (10")
B744VL	381mm (15")

Hull Types (see Figure 1)

- Displacement hull powerboat**—Locate 1/3 aft LWL and 150–300mm (6–12") off the centerline. The starboard side of the hull where the propeller blades are moving downward is preferred.
- Planing hull powerboat**—Mount well aft near the centerline and *well inboard of the first set of lifting strakes* to insure that it is in contact with the water at high speeds. The starboard side of the hull where the propeller blades are moving downward is preferred.

Outboard and I/O—Mount forward and to the side of the engine(s).
Inboard—Mount well ahead of the propeller(s) and shaft(s).
Stepped hull—Mount just ahead of the first step.
Boats capable of speeds above 25kn (29MPH)—Review multisensor location and operating results of similar boats before proceeding.

- Fin keel sailboats**—Mount to the side of the centerline and forward of the fin keel 300–600mm (1–2').
- Full keel sailboats**—Locate amidships and away from the keel at the point of minimum deadrise angle.

Installation

The following instructions are for a Standard Fairing ONLY.

WARNING: *The B744V and B744VL must be installed with a fairing (High-Performance or Standard). If the multisensor is installed without a fairing, there is insufficient surface area around the drilled hole to seal it to the hull. Water may leak into the hull causing damage to the boat or possibly sinking.*

WARNING: *A High-Performance Fairing must be installed following the installation instructions that come with the fairing. The High-Performance Fairing requires an anti-rotation bolt. Failure to install the anti-rotation bolt may result in the fairing rotating while the boat is underway. The effect may be violent movement and loss of steering. This could result in serious injury or death to passengers and/or damage to the boat or other property.*

Cored Fiberglass Hull—Follow separate instructions on page 5

Hole Drilling

Warning: *Always wear safety goggles and a dust mask.*

- Drill a 3mm or 1/8" pilot hole perpendicular to the waterline from inside the hull (see Figure 2). If there is a rib, strut, or other hull irregularity near the selected mounting location, drill from the outside.
- Using the 51 mm or 2" hole saw, cut a hole from outside the hull. *Be sure to hold the drill plumb*, so the hole will be perpendicular to the water surface.
- Sand and clean the area around the hole, inside and outside, to ensure that the sealant will adhere properly to the hull. If there is any petroleum residue inside the hull, remove it with either mild household detergent or a weak solvent (alcohol) before sanding.

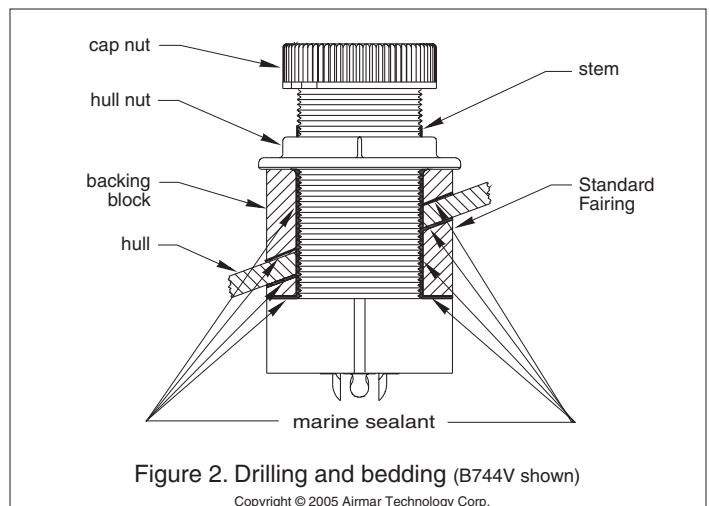

Figure 2. Drilling and bedding (B744V shown)

Copyright © 2005 Airmar Technology Corp.

Cutting the Standard Fairing

High-Performance Fairing—For your safety it is mandatory to follow the Installation Instruction Supplement that comes with the fairing.

1. Measure the deadrise angle of the hull at the selected location using an angle finder or a digital level (see Figure 3).
2. Tilt the band saw table to the measured angle and secure the cutting fence (see Figure 4).

Caution: The **BUTTON** always points forward toward the bow. Be sure to orient the fairing on the band saw so the angle cut matches the intended side of the hull and not the mirror image.

3. Place the Standard Fairing on the table, so the cutting guide rests against the fence. The button will point toward you for installation on the port side and away from you for installation on the starboard side of the boat (see Figures 4 and 5).
4. Adjust the cutting fence. The Standard Fairing *must* be between 6–12mm (1/4–1/2") at its thinnest dimension (see Figure 3).

Warning: Always wear safety goggles and a dust mask.

5. Recheck steps 1 through 4. Then cut the fairing.
6. Shape the fairing to the hull as precisely as possible with a rasp or power tool.
7. Use the remaining section of the fairing for the backing block.

Bedding the Housing

1. Apply a 2mm (1/16") thick layer of marine sealant over the surface of the multisensor housing that will contact the fairing and up the stem. The sealant *must* extend 6mm (1/4") higher than the combined thickness of the fairing, hull, backing block, and hull nut (see Figure 2). This will ensure there is marine sealant in the threads to seal the hull and hold the hull nut securely in place.
2. Slide the fairing onto the stem and mate the button with the recess in the housing (see Figure 5).
3. Apply a 2mm (1/16") thick layer of marine sealant to the side of the fairing that will contact the hull (see Figure 2).
4. Apply a 2mm (1/16") thick layer of marine sealant to the side of the backing block that will contact the hull interior.

Installing the Housing

Caution: Never strike the multisensor.

1. From outside the hull, push the stem of the multisensor housing through the mounting hole using a twisting motion to squeeze out excess sealant. Be sure the button on the fairing is mated with the recess in the multisensor and it is pointing forward toward the bow (see Figure 5). **Take care to align the assembly parallel to the centerline of the boat.**
2. From inside the hull, slide the backing block onto the stem and seat it firmly against the hull. Screw the hull nut in place. Tighten it with slip-joint pliers (see Figure 2).
Wood hull—Allow the wood to swell before tightening.
Cored fiberglass hull—Do not over tighten, crushing the hull.

Caution: Be careful to avoid cross threading the cap nut.

3. Being sure the valve assembly is seated firmly in the housing, carefully screw the cap nut in place. **HAND-TIGHTEN** only. Do not over tighten.
4. Remove any excess sealant on the outside of the fairing and the hull to ensure smooth water flow over the multisensor.

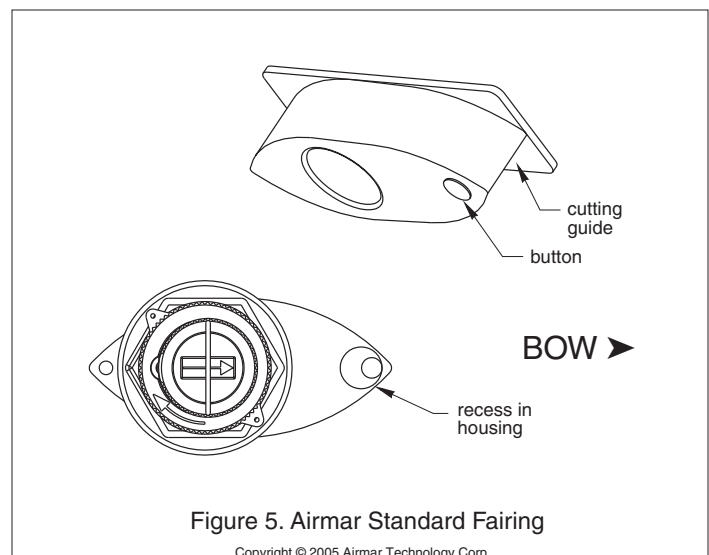
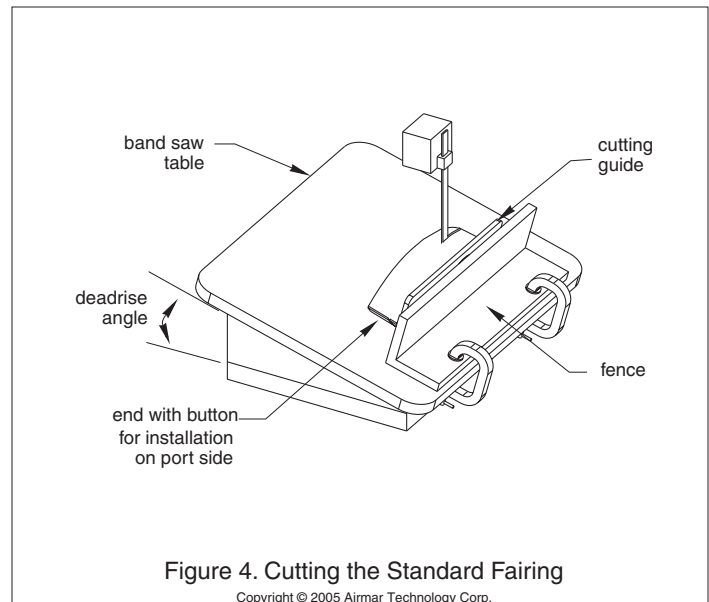
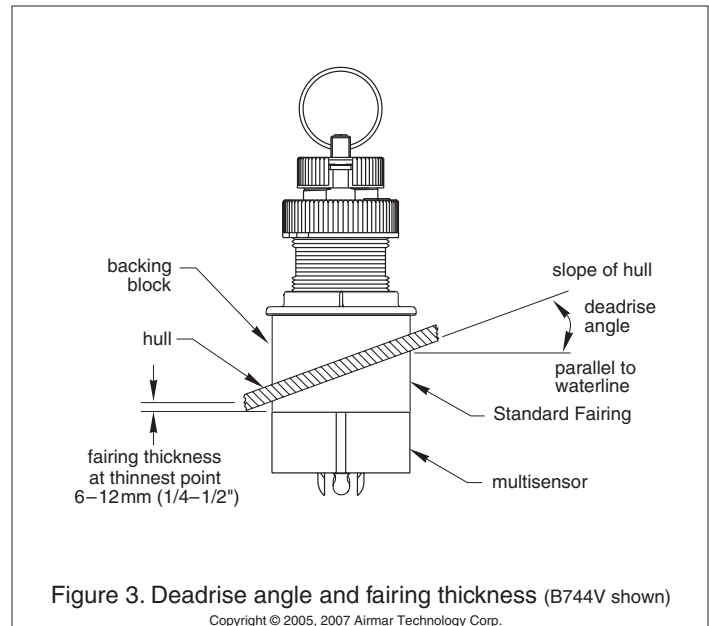

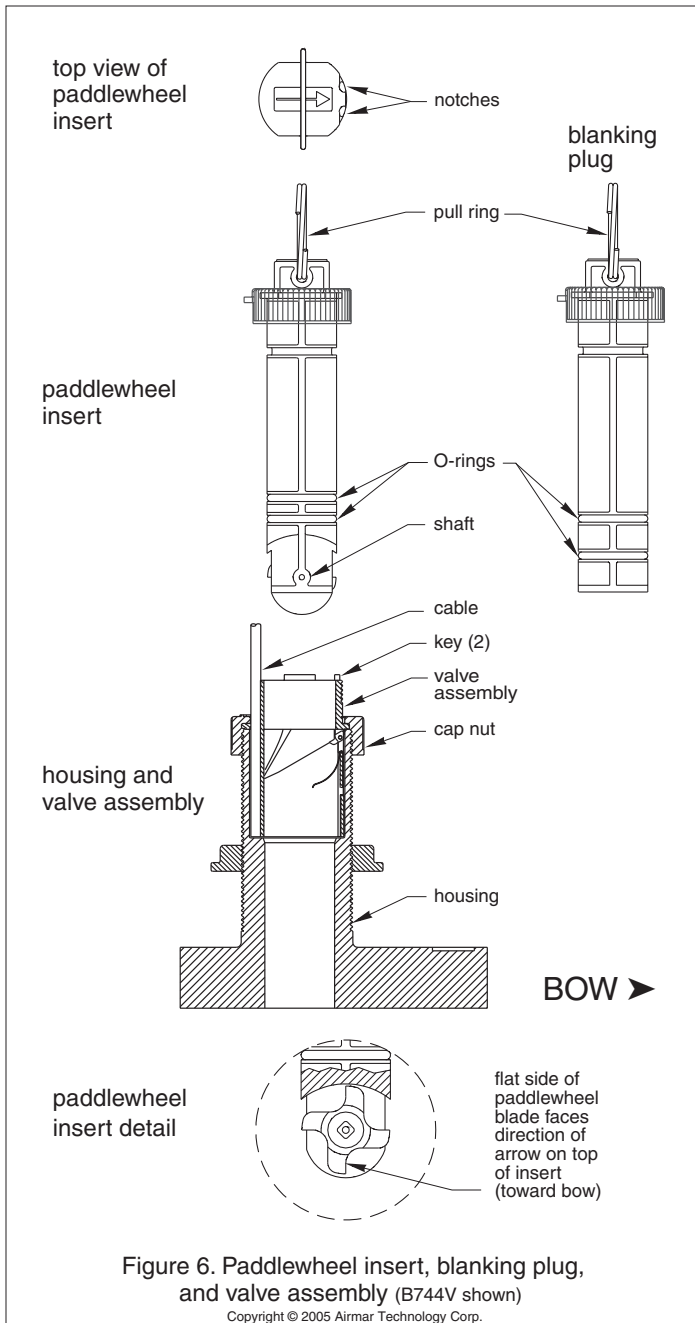

Installing the Paddlewheel Insert

Caution: Never, pull, carry, or hold the multisensor by its cable as this may sever internal connections.

WARNING: The O-rings must be intact and well lubricated to make a watertight seal.

1. After the sealant cures, inspect the O-rings on the paddlewheel insert (replace if necessary) and lubricate them with the silicone lubricant supplied (see Figure 6).
2. Slide the paddlewheel insert into the housing with the *arrow on the top pointing forward toward the bow*. Seat it into place using a twisting motion until the keys fit into the notches. (The insert fits one way only.) *Be careful* not to rotate the outer housing and disturb the sealant. Screw the insert nut in place and **HAND-TIGHTEN** only. *Do not* over tighten.

Warning: Always attach the safety wire to prevent the insert from backing out in the unlikely event that the cap nut and/or insert nut fails or is screwed on incorrectly.

3. Attach the safety wire. Wrap one end of the safety wire tightly around the stem of the housing and twist it together with the long end (see Figure 7). Keeping the wire taut throughout, lead the wire straight up and through one eye in the *cap* nut. Thread the wire through the eye a second time. Lead the wire in a counterclockwise direction and thread it through the eye in the *insert* nut. Thread the wire through that eye a second time. Loop the wire through the pull ring and twist the wire securely to itself.

Caution: If the multisensor came with a connector, do not remove it to ease cable routing. If the cable must be cut and spliced, use Airmar's splash-proof Junction Box No. 33-035 and follow the instructions provided. Removing the waterproof connector or cutting the cable, except when using Airmar's junction box, will void the multisensor warranty.

4. Route the cable to the instrument, *being careful* not to tear the cable jacket when passing it through the bulkhead(s) and other parts of the boat. To reduce electrical interference, separate the multisensor cable from other electrical wiring and the engine. Coil any excess cable and secure it in place using zip-ties to prevent damage.
5. Refer to the echosounder owner's manual to connect the multisensor to the instrument.

Check for Leaks

Warning: DO NOT leave the boat in the water unchecked for several days.

When the boat is placed in the water, **immediately** check the thru-hull multisensor for leaks. Note that very small leaks may not be readily observed. *Do not* leave the boat in the water for more than 3 hours before checking it again. If there is a small leak, there may be considerable bilge water accumulation after 24 hours. If a leak is observed, repeat "Bedding the Housing" and "Installing the Housing" **immediately** (see page 3).

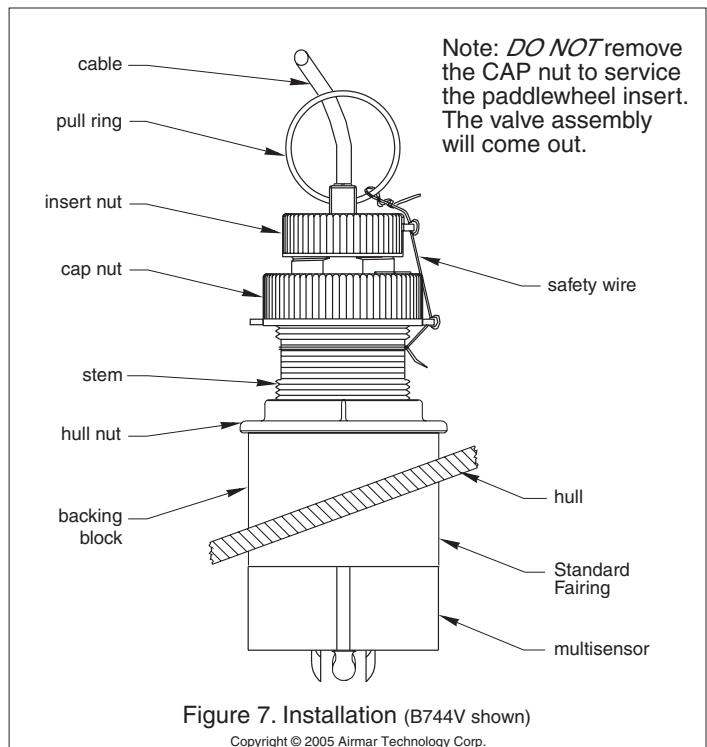

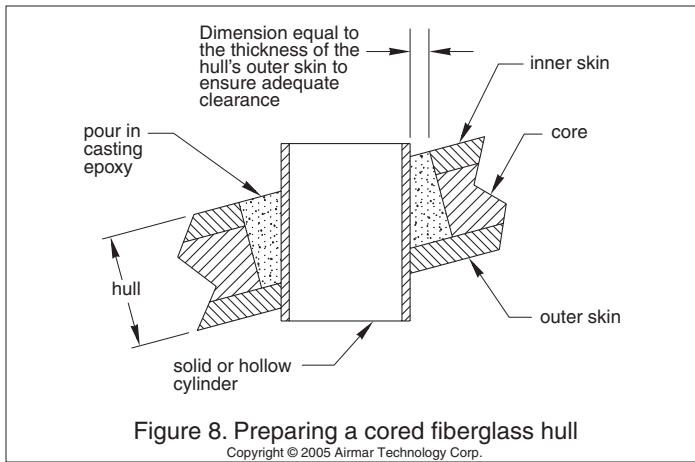

Installation in a Cored Fiberglass Hull

The core (wood or foam) *must* be cut and sealed carefully. The core *must* be protected from water seepage, and the hull *must* be reinforced to prevent it from crushing under the hull nut allowing the housing to become loose.

Warning: Always wear safety goggles and a dust mask.

1. Drill a 3mm or 1/8" pilot hole perpendicular to the waterline from inside the hull (see Figure 8). If there is a rib, strut, or other hull irregularity near the selected mounting location, drill from the outside. (If the hole is drilled in the wrong location, drill a second hole in a better location. Apply masking tape to the outside of the hull over the incorrect hole and fill it with epoxy.)
2. Using the 51 mm or 2" hole saw, cut a hole from outside the hull through the *outerskin* only. *Be sure* to hold the drill plumb, so the hole will be perpendicular to the water surface.
3. The optimal interior hole diameter is affected by the hull's thickness and deadrise angle. It *must* be large enough in diameter to allow the core to be completely sealed. Using the 60mm or 2-3/8" hole saw, cut through the *inner* skin and most of the core from inside the hull keeping the drill perpendicular to the hull. The core material can be very soft. Apply only light pressure to the hole saw after cutting through the *inner* skin to avoid accidentally cutting the *outerskin*.
4. Remove the plug of core material so the *inside* of the outer skin and inner core of the hull is fully exposed. Sand and clean the inner skin, core, and the outer skin around the hole.

Caution: Completely seal the hull to prevent water seepage into the core.

5. Coat a hollow or solid cylinder of the correct diameter with wax and tape it in place. Fill the gap between the cylinder and hull with casting epoxy. After the epoxy has set, remove the cylinder.
6. Sand and clean the area around the hole, inside and outside, to ensure that the sealant will adhere properly to the hull. If there is any petroleum residue inside the hull, remove it with either mild household detergent or a weak solvent (alcohol) before sanding.
7. Proceed with "Bedding the Housing" on page 3.

Antifouling Paint

Aquatic growth can accumulate rapidly on the multisensor's surface reducing performance within weeks. Surfaces exposed to salt water *must* be coated with antifouling paint. Use *WATER-BASED* antifouling paint only. *Never* use ketone-based paint since ketones can attack many plastics possibly damaging the transducer. Reapply paint every 6 months or at the beginning of each boating season.

Paint the following surfaces (see Figure 9):

- Exposed areas of the housing including the acoustic window
- Bore of the housing up 30mm (1-1/4")
- Outside wall of the paddlewheel insert below the lower O-ring
- Paddlewheel cavity
- Paddlewheel
- Blanking plug below the lower O-ring including the exposed end

Operation & Maintenance

Winterizing

After the boat has been hauled for winter storage, remove the blanking plug to let the water drain away before reinserting it. This will prevent any water from freezing around the blanking plug and possibly cracking it.

How the Valve Works

WARNING: THE VALVE IS NOT A WATERTIGHT SEAL!
Always install the paddlewheel insert or the blanking plug secured with the insert nut and safety wire for a watertight seal.

The multisensor incorporates a self-closing valve which minimizes the flow of water into the vessel when the paddlewheel insert is removed. The curved flap valve is activated by both a spring and water pressure. Water pushes the flap valve upward to block the opening, so there is no gush of water into the boat (see Figure 6).

Using the Blanking Plug

To protect the paddlewheel, use the blanking plug:

- When the boat will be kept in salt water for more than a week.
- When the boat will be removed from the water.
- When aquatic growth buildup on the paddlewheel is suspected due to inaccurate readings from the instrument.

WARNING: The O-rings must be intact and well lubricated to make a watertight seal.

1. On the blanking plug, inspect the O-rings (replace if necessary) and lubricate them with silicone lubricant or petroleum jelly (Vaseline®) (see Figure 6).

Warning: Do not remove the CAP nut. The valve assembly will come out.

2. Remove the paddlewheel insert from the housing by removing the safety wire from the pull ring and the *insert* nut. Unscrew the *insert* nut (see Figure 7). *Do not remove the CAP nut.*

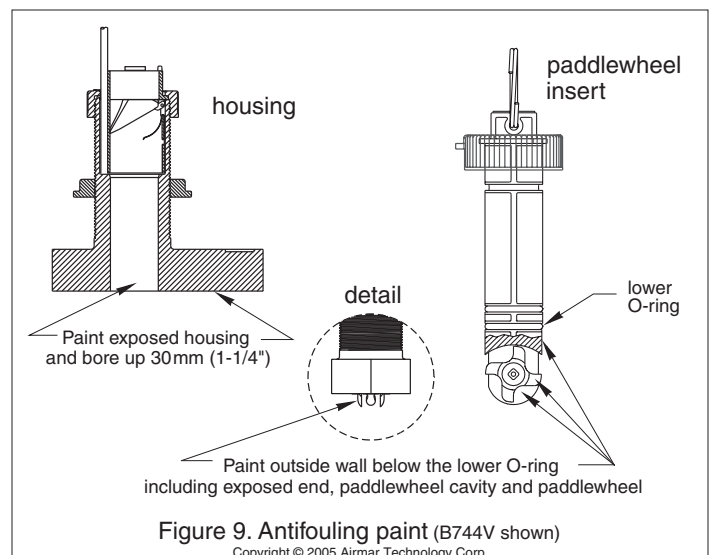

3. Grasp the pull ring and remove the paddlewheel insert with a slow pulling motion.

Note: *In the unlikely event that the paddlewheel insert cannot be removed, see "Servicing the Valve Assembly".*

Warning: *Always attach the safety wire to prevent the insert from backing out in the unlikely event that the cap nut and/or insert nut fails or is screwed on incorrectly.*

4. Slide the blanking plug into the housing. Seat it into place with a pushing twisting motion until the keys fit into the notches (see Figure 6). Screw the insert nut in place and **HAND-TIGHTEN** only. *Do not* over tighten. Reattach the safety wire (see Figure 7).

Cleaning the Multisensor

Aquatic growth can accumulate rapidly on the multisensor's surface, reducing its performance within weeks. Clean the surface with mild household detergent and a Scotch-Brite® scour pad. If fouling is severe, push out the paddlewheel shaft using a spare shaft or a 4D finish nail with a flattened point. Then lightly wet sand the paddlewheel with fine grade wet/dry paper.

Servicing the Paddlewheel Insert

The water lubricated paddlewheel bearings have a life of up to 5 years on low-speed boats [less than 10kn (11 MPH)] and 1 year on high-speed vessels. Paddlewheels can fracture and shafts can bend due to impact with water borne objects and mishandling in boat yards. O-rings *must* be free of abrasions and cuts to ensure a watertight seal. Order a replacement Paddlewheel Kit No. 33-113.

- Using the new paddlewheel shaft, push out the old shaft about 6 mm (1/4"). With pliers, remove the old shaft (see Figure 6).
- Place the new paddlewheel in the cavity with the flat side of the blade facing the same direction as the arrow on the top of the insert.
- Tap in the new shaft into place until the ends are flush with the sides of the insert.
- Install two O-rings in the *lower* groves near the paddlewheel. *Do not* place them near the pull ring.
- The remaining two O-rings are placed in a similar position on the blanking plug.
- To reinstall the paddlewheel insert, see "Installing the Paddlewheel Insert" on page 4.

Servicing the Valve Assembly

Should the valve fail, remove it for servicing. Order a replacement Paddlewheel and Valve Kit No. 33-218.

WARNING: *The blanking plug cannot be secured without the valve assembly. After removing the valve assembly, temporarily insert the blanking plug, but do not leave the boat in the water unattended. THIS IS NOT A WATERTIGHT OR SECURE SEAL!*

Warning: *O-rings must be intact and well lubricated to make a watertight seal.*

- On the blanking plug, inspect the O-rings (replace if necessary) and lubricate them with silicone lubricant or petroleum jelly (Vaseline®) (see Figure 6).
- Remove the safety wire and unscrew the *cap* nut (see Figure 7). With the blanking plug ready in one hand, *remove the paddlewheel insert and valve assembly as one unit* by grasping the pull ring and pulling upward. Rapidly replace the valve assembly with the blanking plug to minimize the flow of water into the boat. **TEMPORARILY** secure it with the safety wire.

3. Separate the paddlewheel insert from the valve assembly by unscrewing the insert nut (see Figure 6). Grasp the pull ring and pull slowly upward.

Warning: *If a new valve assembly is required and not immediately available, the valve sleeve must be reinstalled in the multisensor housing for a watertight seal. Remove the flap valve, spring pin, and spring from the sleeve before reinstalling.*

4. Clean, repair, or replace the valve assembly so the flap valve moves freely and seats against the sleeve (see Figure 10).

WARNING: *The O-rings must be intact and well lubricated for a watertight seal.*

5. To reinstall the valve assembly, inspect the O-rings on the paddlewheel insert (replace if necessary) and lubricate them with silicone lubricant or petroleum jelly (Vaseline®) (see Figure 6)

6. Slide the paddlewheel insert into the valve assembly. Seat it in place with a twisting motion until the keys fit into the notches. Secure the paddlewheel insert with the insert nut. **HAND-TIGHTEN** only. *Do not* over tighten.

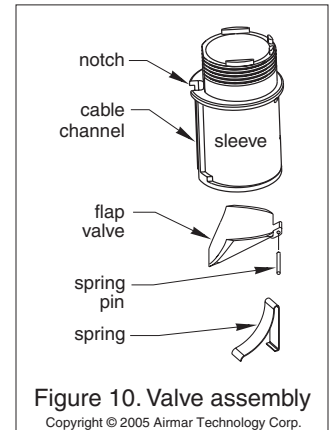

Figure 10. Valve assembly
Copyright © 2005 Airmar Technology Corp.

Caution: *Be careful to avoid cross threading the cap nut.*

7. Remove the safety wire from the multisensor. With the combined valve assembly and paddlewheel insert ready in one hand, remove the blanking plug. Slide the assembly into the multisensor housing *with the arrow on the top pointing forward toward the bow*. Be sure the cable fits into the cable channel and the notch in the sleeve fits into the key in the housing (see Figure 10). (A pushing twisting motion will locate the key.) Screw the *cap* nut in place and **HAND-TIGHTEN** only. *Do not* over tighten.

Warning: *Always attach the safety wire to prevent the insert from backing out in the unlikely event that the insert nut and/or cap nut fails or is screwed on incorrectly.*

8. Reattach the safety wire (see Figure 7).

Replacement Multisensor & Parts

The information needed to order a replacement Airmar multisensor is printed on the cable tag. *Do not* remove this tag. When ordering, specify the part number, date, and frequency in kHz. For convenient reference, record this information at the top of page one.

Lost, broken, or worn parts should be replaced immediately.

Model	Cap Nut	Hull Nut	Standard Fairing	High-Performance Fairing	Blanking Plug	Insert
B744V	04-234-1	02-030	04-469-01	33-476-01	33-551-01	NA
B744VL	04-234-1	02-030	04-469-01	33-476-01	NA	NA

Paddlewheel Kit 33-113
Paddlewheel & Valve Kit 33-535-01

Obtain parts from your instrument manufacturer or marine dealer.

Gemeco (USA) Tel: 843.394.3565
Fax: 843.394.3736
email: sales@gemeco.com

Airmar Europe Tel: +45.45.81.04.18
Fax: +45.45.81.04.93
email: sales@airmareurope.com

AIRMAR®
TECHNOLOGY CORPORATION

35 Meadowbrook Drive, Milford, New Hampshire 03055-4613, USA

▪ www.airmar.com

Copyright © 2004, 2006, 2007 Airmar Technology Corp. All rights reserved.