



Sliding Window Channel – Installation Instructions

StanPro Marine Channel - Part# 75000119

StanPro Marine Flexible Channel - Part# 75000118

StanPro Marine Edge Channel - Part# 75000081

StanPro Marine Double Channel - Part# 75000120

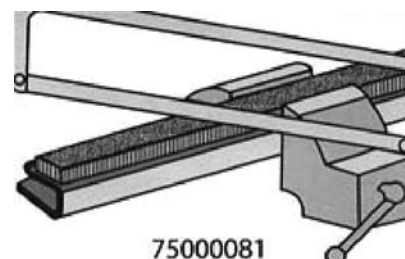
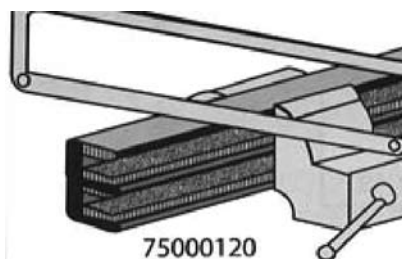
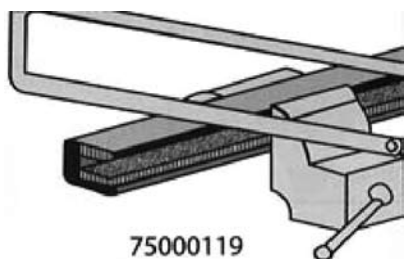

All channels can be cut with hacksaw, except 75000118 (use bandsaw or tin snips). When using a hack saw on 75000119, 75000120, or 75000081, hold the channel in a vise and saw as shown to prevent loosening of pile and beading.

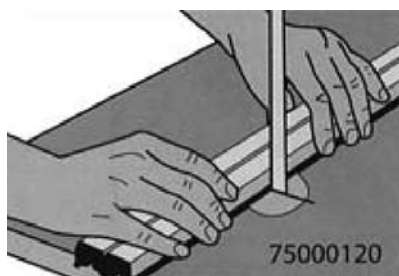
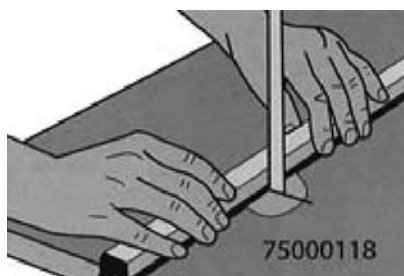

When using band saw on 75000118, 75000119, 75000120 or 75000081, be sure it has a metal cutting blade. Feed into saw slowly with both beads down on work surface.

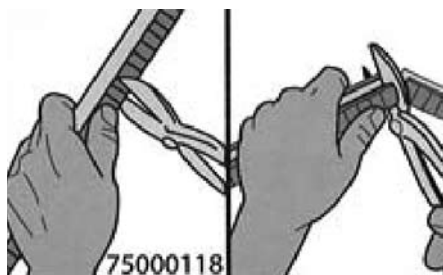

Tin snips can be used to cut 75000118. When using tin snips, cut each side separately, cutting from the bead to the bottom, then fold back the bottom and cut square.

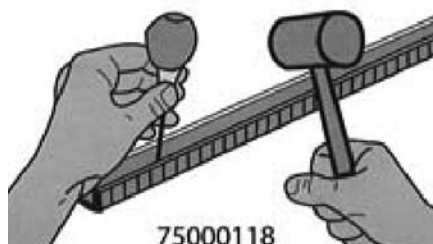

An ice pick or scribe can be used to punch screw holes in the bottom of 75000118. It is recommended that 3/4" x #5 flat-head brass screws on 12" centers be used. Channel should be screwed down deep enough into nylon bottom to assure glass clearance.

Note: Do not butt pieces of channel for the lower sill, because it will cause leakage. Butting of pieces for upper or end channel can be done, but proper alignment is important. Mating of channels at corners should be done by cutting chamfers just under beading.



Sliding Window Channel – Installation Instructions (Cont.)

Cut scupper or drain holes at each end to match drains leading to the outside of cabin. Pry nylon bottom at end up through pile and pull channel out for several inches. Drain shown may be cut with tin snips on center leg and with a saw or chisel on bottom. Bend scrap piece back and forth until it fractures.

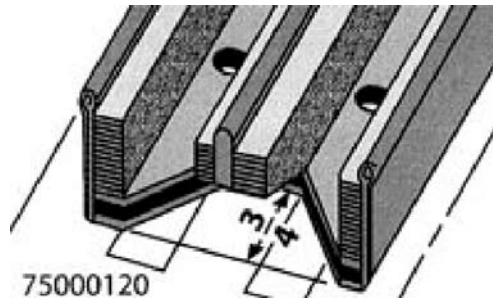
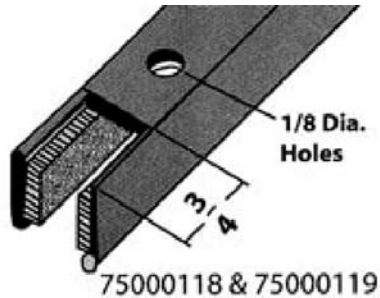

Drain shown above may be made with a saw cut across the bottom and tin snips cuts made parallel to sides. Cut nylon strips to match opening and push into place. Drill 1/8" holes through nylon felt and stainless channel for No. 5 flathead brass screws, 3/4" long. Use 1/16" diameter drill for wood screw pilot holes in framework at 12" centers; screws to be set deep enough into nylon to ensure glass clearance.

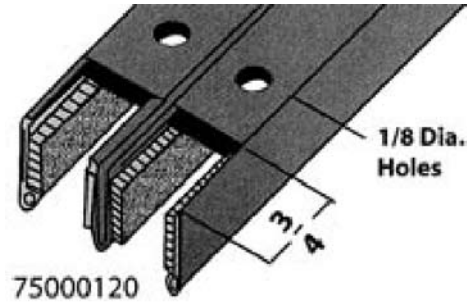
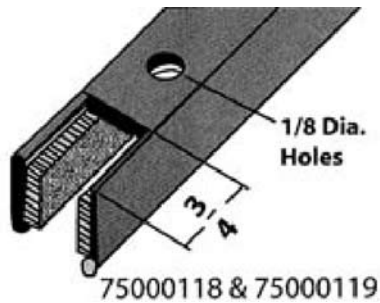

When installing 75000081 edge channel, place rubber glass setting tape (Sealstrip Part# 75000662) over edge of glass. Properly position edge channel over tape and hammer onto glass. To avoid denting channel, place hardwood block against channel and hammer on wood.

