

Installation Instructions Fuel Level Sender

Metric Marine
10-180 OHM Single Station
5-90 OHM Dual Station

CAUTION

READ ALL INSTRUCTIONS THOROUGHLY BEFORE INSTALLATION. IF YOU ARE NOT EXPERIENCED IN WORKING WITH FUEL TANKS, SEEK PROFESSIONAL ASSISTANCE.

DISCONNECT BATTERY BEFORE PROCEEDING!

ANY TYPE OF WORK INVOLVING FUEL TANK REPAIR OR MODIFICATION SHOULD BE PERFORMED WITH EXTREME CARE. DUE TO THE POSSIBILITY OF IGNITING FUEL FUMES, THE TANK SHOULD BE EMPTY, DRY, AND PURGED OF FUMES.

WORK SHOULD BE PERFORMED IN A WELL VENTILATED AREA.

ONLY TOOLS THAT WILL NOT CREATE POSSIBLE FUEL IGNITION SPARKS SHOULD BE USED.

FAILURE TO COMPLY WITH INSTALLATION INSTRUCTIONS MAY RESULT IN UNSATISFACTORY INSTRUMENT PERFORMANCE. IMPROPER INSTALLATION OR USE OF THE PRODUCT FOR AN APPLICATION OTHER THAN ITS INTENDED USE WILL VOID YOUR WARRANTY AND COULD RESULT IN SERIOUS PERSONAL INJURY.

TOOLS YOU WILL NEED

Tape Measure
Hacksaw
Wire Cutters
Terminal Crimper or Pliers
3/8" Wrench

Part I: Adjusting the Sender

1. Measure the depth of the tank down through the large hole. On the Fuel Level Sender measure down from the bottom of the mounting flange 1/2 of your tank depth dimension. Mark the pivot support at that dimension as shown in Illustration A. The nearest hole **at or above** your mark will be the new mounting location of the float arm pivot.

2. Note on which side of the float pivot support the pivot is mounted. The pivot must be remounted on the same side of the support. Remove the hex nut and lock washer holding the pivot and remove the pivot from the support. **Be careful not to damage the pivot or any wire when cutting the support.**

If the float pivot support is too long for the depth of the tank, you must cut off the excess with a hacksaw 13mm below your selected hole.

Carefully wrap the wire once or twice around the support (see illustration A) so it does not interfere with the float arm. Be sure the wire is loose and the float pivot is on the correct side of the support. Remount the float pivot at the selected hole, replace the lock washer, and tighten the hex nut.

IMPORTANT: Be sure that the wire connection is at the bottom of the pivot and the "T" head of the mounting bolt rests in its slot and against the metal plate, as shown in illustration B, or the sender will not operate properly.

ILLUSTRATION A

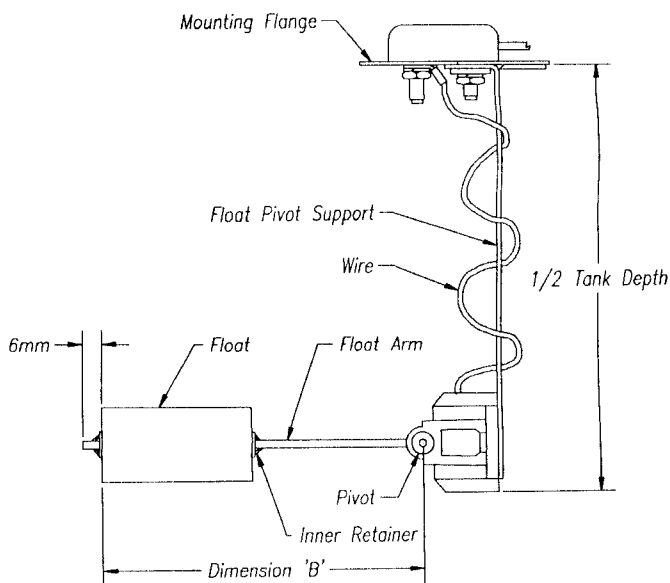

3. Slide the float and outer retainer toward the pivot along the float arm to dimension B selected in the table as shown illustration A. Leave about 6 mm of the arm beyond the outer retainer and cut off the excess. **Do not position the inner retainer at this time.**

4. Insert the float/float arm assembly into the tank hole, and lower the sender until the mounting flange makes contact with the top of the tank. **Make sure the flange is positioned flat against the tank.** The float should hang freely and **not contact the bottom of the tank.** If the float contacts the bottom of the tank, slide the float and the retainer 6 mm up the arm towards the pivot and trim the excess as in step 3. Try the fit again, and repeat this step as necessary for the float to hang freely. Now you may slide the inner retainer against the float.

ILLUSTRATION B

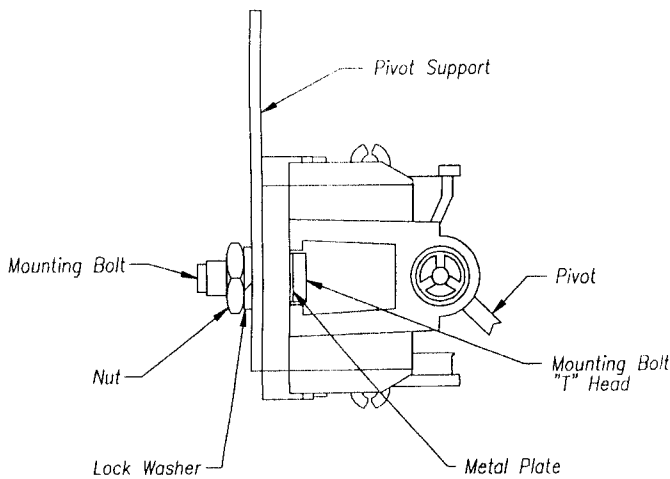
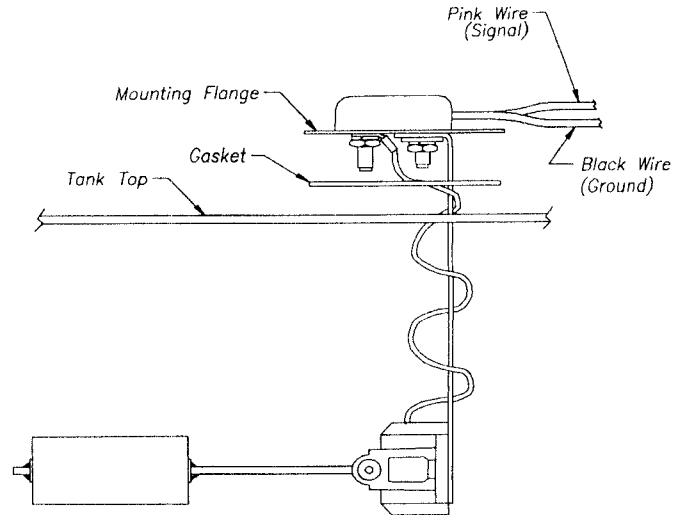

ILLUSTRATION C



Float Rod Dimension Table
Faria Universal Level Sender

Tank Depth	"B" Dimension
203mm	102mm
229mm	117mm
254mm	137mm
279mm	152mm
305mm	171mm
330mm	184mm
356mm	203mm
381mm	219mm
406mm	235mm
432mm	254mm
457mm	270mm
483mm	286mm
508mm	302mm
533mm	318mm
559mm	337mm
584mm	352mm
610mm	386mm
635mm	387mm

NOTE: If you find that when aligning the holes, the float arm hits the tank side, a baffle, or a pick-up tube, it will be necessary to rotate the float arm pivot support. Slightly loosen the nut holding the pivot support to the mounting flange and rotate the float pivot support until the float arm hangs free in the desired location. (In most powerboat applications the float arm should point forward). Gently retighten the nut and proceed.

2. Gently turn all the screws or nuts until they just contact the mounting flange. Snug the screws or nuts in opposite sequence. If you do this in several stages it will ensure that the mounting flange evenly compresses the gasket. **Do not over tighten** as you may strip out threads in tank top.
3. Connect the end of the black ground wire to ground. Connect the pink signal wire to the signal wire of the gauge.

Your installation is now complete.

CAUTION!! OBSERVE THE FUEL TANK DURING INITIAL OPERATION TO BE SURE THERE ARE NO LEAKS!

Part II: Installing the Sender

1. The entire installation is shown in illustration C.

Place the gasket on the tank top and rotate it until all the holes align properly. Lower the float into the tank and lower the sender until the mounting flange is flat on the gasket and all the holes align properly.

IMPORTANT: USE ONLY THE FARIA GASKET SUPPLIED WITH THE LEVEL SENDER. THE USE OF ANY OTHER GASKET COULD EFFECT THE FUNCTION OF THE SENDER, RESULT IN DAMAGE TO THE SENDER OR MAY NOT PROVIDE A RELIABLE SEAL BETWEEN THE TANK AND SENDER.

385 Norwich New London Tpke., P.O. Box 983, Uncasville, CT 063982
Customer Service: (800) 473-2742 FAX: (860) 848-2704