

Installation Instructions

Magnetic Pick-up Tachometer/ Tach-Hourmeter

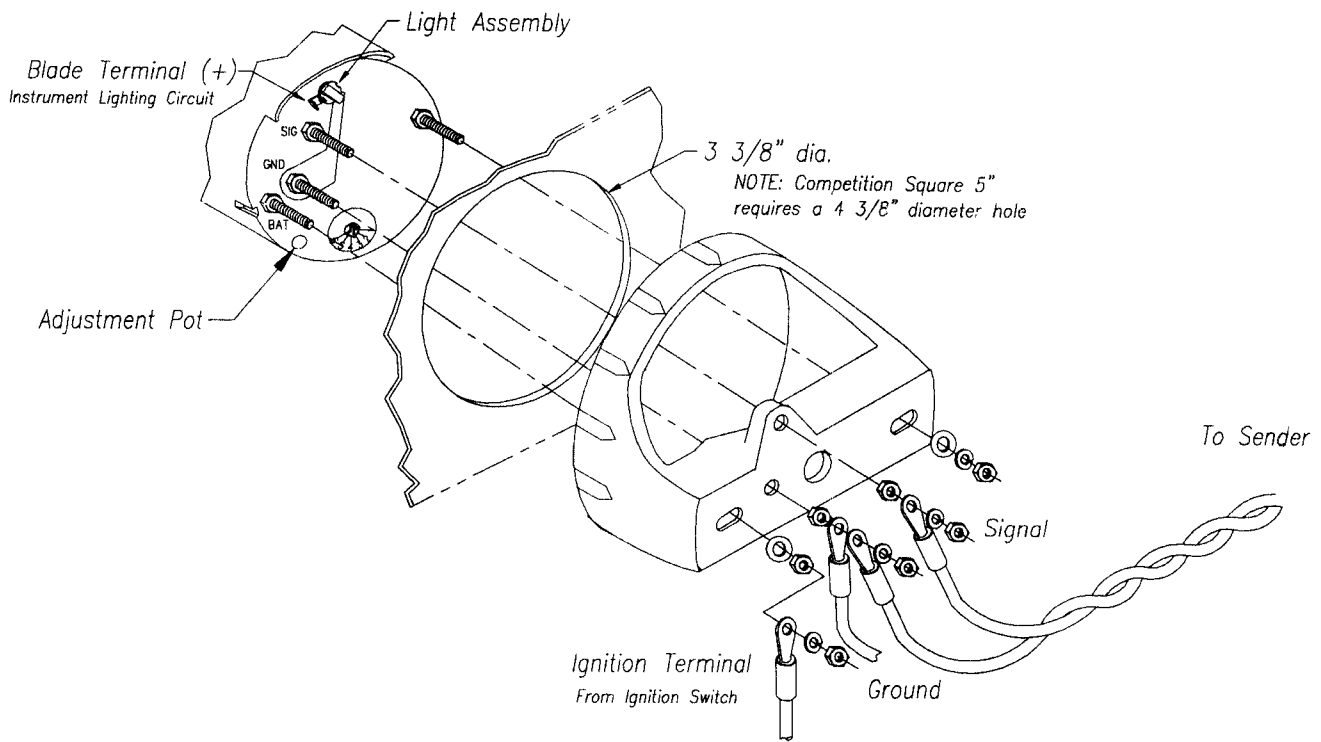

1. **CAUTION:** Disconnect the battery during installation. Tighten nuts on the back clamp only slightly more than you can tighten with your fingers. Six **inches** of torque is sufficient. Over tightening could result in damage to the instrument and may void your warranty!
2. Location: The tachometer should be located at least 18" from a magnetic compass. Some interference (erratic operation) may be noticed on the tachometer during radio transmissions. This will neither damage a Faria tachometer nor affect accuracy when not transmitting.
3. Cut a 3 3/8" diameter hole in the dash and mount the tachometer with the back clamp supplied.
4. Be certain to use stranded, insulated wire not lighter than 18 AWG that is approved for marine use. It is recommended that insulated wire terminals, preferably ring type, be used on all connections to the tach, except the light, which requires a 1/4" female blade terminal.
5. Connect a wire to the tach stud marked "BAT" (battery) and secure with a nut and lock washer. Connect opposite end to a 12VDC circuit that is activated by the ignition switch.

6. Connect a wire to the tach stud marked "GND" (ground) and secure with a nut and lock washer. Connect the opposite end to the boat's electrical ground, generally available in several locations at or near the instrument panel.

7. Connect the blade terminal adjacent to the twist-out light assembly to the positive "+" side of the boat's instrument lighting. Reconnect the battery.

8. To connect sender, refer to the installation and calibration addendum on reverse side of this sheet.

9. **NOTE:**

A) To change light bulb; twist black socket assembly one-eighth turn counter clockwise until it pops out. Bulb pulls out of socket assembly. It is a GE No. 194 instrument lamp.

B) If your tachometer is equipped with an hourmeter, the hourmeter will be energized when the engine is running.

Addendum:

The following installation information is unique to tachometers operating off of Magnetic Pick-up (Flywheel) senders on Diesel engines. Please read these instructions before beginning tachometer installation.

The output signal provided to the tachometer from typical flywheel located magnetic pick-up senders is very weak (especially at idle speeds) compared to an alternator tach source or a pulse generator tach source. Accordingly, the input sensitivity of the *Faria* Mag Pick-up tachometer has been increased to ensure reliable performance with these weaker Mag Pick-up signals. Because of this increased input sensitivity, additional precautions should be taken during installation to minimize the possibility of picking up stray interference signals (Radio Frequency Interference - RFI, and Electro-Mechanical Interference - EMI). Without these precautions, such stray RFI/EMI may cause random erratic tachometer reading or other undesirable side effects.

There are only three connections to the tachometer: Power [+], Ground (for both Power[-] and Signal[-]), and Signal [+]. RFI/EMI can contaminate the leads to any of these three connections unless proper precautions are taken, such as:

1. The Power lines, [+] and [-], should be isolated from circuits that power communications and other electronic equipment. Most boats have separate +12VDC and ground lines run from the batteries to the helm.....one set for engine instrumentation and a second set of +/- Power lines for electronics. In fact, some boats even have a third set of general boat wiring, lighting, bilge pumps, blowers, and other electric accessories. The tachometer should be connected to the power lines dedicated to the engine instrumentation. The power lines to the tachometer should be Purple [+] and Black [-] 16 AWG wire, and the [+] lead should be over current protected (fused) with a 1/2 AMP Slo-Blow fuse.
2. The magnetic pick-up sender usually located on the engine's flywheel bell housing normally has two connections (terminals or wires) exiting from it. These connections are not polarized, either can be considered the signal [+] or [-]. These two connections (terminals, wires) must be run directly to the tachometer. **DO NOT GROUND ONE OF THE CONNECTIONS AT THE ENGINE!**
3. It is recommended that an 18 AWG twisted pair cable be used to interconnect the sender with the tachometer. (NOTE: USCG and ABYC standards for boat wiring require that individual wires be no lighter than 16 AWG. Wires encased in a common sheath, that is "cables", may be as light as 18 AWG provided that the pigtailed wires exiting the sheath are no longer than 30 inches.) Connect the Mag Pick-up sender to the twisted pair and route to the tach.
4. Avoid routing the cable in close proximity with other boat wiring as much as possible.....particularly wiring for electronic equipment. Connect one of the wires in the twisted air cable directly to the tachometer's ground terminal and the other directly to the signal terminal.

5. In order to provide universal operation, the *Faria* Diesel Mag Pick-up Tach has been designed to function with flywheels having a wide variety of tooth counts. In order to ease calibration, this wide range is broken down into several switched positions acting as a "course adjustment". Refer to the label on the tachometer to properly set the course adjustment for your engine's tooth count. Slightly depress the switch to rotate and be sure it pops out into a "detent" position.

Calibration: There is some overlap between ranges to assure that there are no "gaps" in the calibration coverage. The "fine adjustment" of calibration is accomplished by varying the calibration TRIMPOT located behind the plastic stop-plug on the rear of tachometer's case. (Refer to figure) Once installation has been completed, proceed with the calibration as follows:

1. If the number of teeth on the flywheel is known, set the calibration "coarse adjustment switch" using a fine blade slotted head screwdriver to their applicable position. If not, then set the calibration switch as well as the trimpot as detailed in Step 2.
2. Set up a calibrated "shop tach" or "strobe tach" to monitor the engine's true RPM*. Start the engine and (after an appropriate warm-up period and with the shift in neutral) increase its speed to the boat's normal cruising RPM as read on the shop tach. (If the "coarse switch" was not set in Step 1, set it now to the position that causes the *Faria* tach to read closest to the true RPM). Adjust the Trimpot for the exact RPM. (Refer to the figure) This is accomplished by removing the stopplug and inserting a flat blade jeweler's screwdriver through the access hole and into the "fine adjustment" calibration trimpot, rotating it CW or CCW as necessary. (some models may have a 5/64th or 1.4 mm hex)
3. Once calibration at the engine's normal cruising RPM has been set, the tachometer will simultaneously be calibrated at all engine speeds. Replace the plug.

This completes the installation and calibration procedure.

- *) Some diesel engines incorporate a governor that limits full throttle RPM to a pre-set level equal to the engine's recommended maximum cruising speed. If your engine has such a governor and if the governed full throttle RPM is known, (it should be clearly stated on the engine's certification documentation), use of a calibrated "shop tach" is not necessary. Simply run the engine up to the governed maximum cruising RPM and calibrate the tach to the rated RPM as specified in the engine's certification documentation.

WARNING! Be absolutely sure that your engine has properly functioning and certified governor before attempting this alternate procedure.