



AIS SART RESCUE BEACON SR500

The SR500 AIS SART is a manually deployed AIS Search and Rescue Transmitter, certified to meet IMO SOLAS Standards. Compact and easy to operate and deploy, the SR500 AIS SART is packed inside a quick release carry bag, that allows a survival crafts location to be identified by rescue authorities and nearby AIS equipped vessels.

The SR500 transmits structured alert messages, GPS position information, and the serialised identity number of the beacon. Once activated the SR500 AIS SART transmits continuously for a minimum of 96 hours, with an inbuilt high precision GPS receiver providing accurate position information to assist in the detection of the survival crafts' location.

Whether wall mounted in the ships bridge or packed inside a survival craft, the high visibility, buoyant carry case is easy to locate in the event of an emergency.

Features

- AIS SART (Rescue Beacon)
- Integrated GPS Position is Sent Over AIS 1 & 2 VHF Channels
- Signal Transmitted at 1W for 96 Hours Minimum
- Compatible with Chart Plotter Packet Standards
- Position Transmitted Every 1 Minute
- High Brightness LED Flashes Morse Code "SOS" Every 30 Seconds



Specifications

GENERAL	
Applicable Standards:	IEC 61097-14 Ed.1 (2010)
	IEC 60945 Ed. 4 (2002) incl. Corrigendum 1 (2008)
	IMO Resolution MSC.246 (83)
	ITU-R M.1371-5 (2014)
VHF PERFORMANCE	
Operating Frequency	AIS 1, 161.975MHz
	AIS 2, 162.025MHz
Data Rate	9,600 bps
Bandwidth	25 KHz
Power Output	1W EIRP
AIS Message Type	Message 1, Message 14
Modulation	GMSK
Antenna	Integrated by PCB
GPS RECEIVER	
Receiving Channels	48 Channels
Acquisition Sensitivity	(-)-159 dBm
Tracking Sensitivity	(-)-159 dBm
Position Accuracy	< 2.5 m Autonomous & SBAS
BATTERY	
Type	Primary Lithium (not rechargeable)
Operating Time	96 Hours Minimum
Storage	6 Years
Service	Replaceable

ENVIRONMENTAL	
Operating Temperature	-20°C~55°C
Storage Temperature	-30°C~70°C
Waterproof	Immersion to 10m
Buoyancy	Floats
Exterior Finish	Highly Visible Yellow
Compass Safe Distance	Standard Magnetic – 0.60m
	Steering Magnetic – 0.40m

PHYSICAL	
Max Diameter (Main Body)	70 mm
Length (Main Body)	300 mm
Weight (Main Body)	283 g (Battery Included)
Length (Pole)	1050 mm (Extended)
Weight (Pole)	300 g
Weight (Storage Package)	1.08 kg

IN THE BOX	
SR500	
Carry Bag	
1m Extension Pole	
10m Buoyant Lanyard	
Wall Mounting Bracket	
Screws M4 x 20	

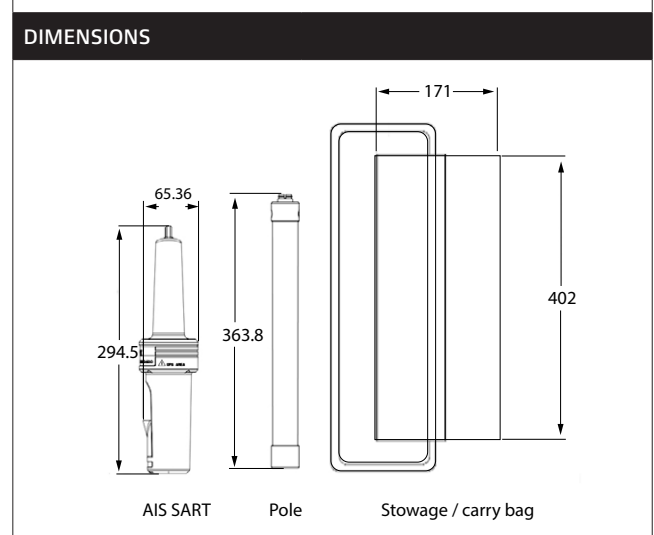

www.gme.net.au

GME Pty Ltd.

Specifications are subject to change without notice, they are issued as a guide only and shall not form part of any contract without the express written authorisation of GME.